

CCM5G Series Coin Changer



Designed to simplify your business through reliable, field-proven performance.

Five-Tube Cassette

Greater capacity eliminates change starvation. Sell more product and avoid costly service calls.

Auto Cassette Programming

Cassettes snap into place and coin configurations are automatically recognized by the changer. No programming needed by service technician, no possibility of error. Optimize sales by interchanging cassettes according to vend price.

3-Coin Payout System

Simultaneous payout of three coins speeds transactions and increases throughput in high-volume locations.

Smart Payout

Unit makes multiple attempts to pay out coins if necessary, virtually ensuring transaction; results in fewer service calls.

Anti-Salting Channel

Unique diversion path protects changer and vendor from salt water vandalism and damage.

Memory Back-Up

Non-volatile memory ensures that changer will retain its settings and transaction history in case of a power failure.

No Tools Required

Designed for easy assembly/disassembly and maintenance, even at vend site.

Swing-Open Payout Base

Swing-open cassette base makes for easy collection and change replenishment. No tools required. Expedites cleaning and removal of foreign material.

Last Coin Payout

No dead inventory.

Warranty

Limited 2 year warranty.



Vendnet, Inc.

165 North 10th Street
Waukee, IA 50263

Toll Free: 1-877-4CONLUX or
1-877-426-6589

Email: Conlux@vendnetusa.com
www.vendnetusa.com

Conlux ... Simply the right choice

Conlux ...

the MEI value brand of bill and coin validator products.



MEI is ISO 9001:2000 Certified



CCM5G Specifications

Interface	Multi-Drop-Bus (M.D.B.)
Operating Voltage	+34VDC
Power Consumption	Standby 0.10A
Operating State	Motor Operation 0.66A Peak Max. 5 sec 0.92A
Operating Temperature Range	50F (-15°C) to 140°F (+60°C)
Insulation Resistance	20M Ohm or more
Weight	4.2 Lbs. (1.9 Kg)
Dimensions	HxWxD: 14.83"H x 5.43"W x 3.23"D (376mm x 147mm x 82mm)
Number of Motors	1 Motor - 15VDC
Number of Solenoids	5 for Coin Selection - 15VDC
Coin Acceptance	US: 5¢, 10¢, 25¢, \$1 CAN: 5¢, 10¢, 25¢, \$1, \$2 Switch Selectable for US only, Canadian only, or both
Cassette Tube	US - 1 Cassette: 1N, 1D, 3Q PN 5030004030 US - 2 Cassette: 2N, 2D, 1Q PN 5030004040 US - 4 Cassette: 1N, 1D, 2Q, \$1 PN 5030004050 US - 5 Cassette: 2N, 3D PN 5030004060

"We have used Conlux coin mechs and validators since June of 2001. I have not come across another brand as reliable and inexpensive as Conlux. Even in the dirtiest conditions, you can count on Conlux to work every time. I would highly recommend their products to everyone in the vending industry."

Darryl Martin
Service Department Manager
D&S/Davians

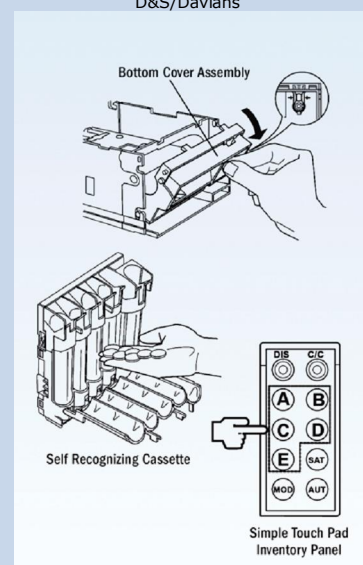

About the Conlux product line

Conlux is the MEI value brand of bill and coin validator products, acquired by MEI in 2003. The Conlux brand is the leading payment systems product in Japan, and has been distributed in North America since 1985. Established in Japan in 1967 to product and sell coin mechanisms for vending machines, Conlux products are designed to simplify business through reliable, field-proven performance.

MEI Corporate Headquarters

1301 Wilson Drive
West Chester, Pennsylvania
19380
1-610-430-2700
1-800-345-8215



Call 1-877-4CONLUX
(1-877-426-6589)

conlux@vendnetusa.com

www.vendnetusa.com