

**CD 5/4 EC**  
**9 SELECTION COMBO**  
**"ELECTRONIC" CONTROL SYSTEM**

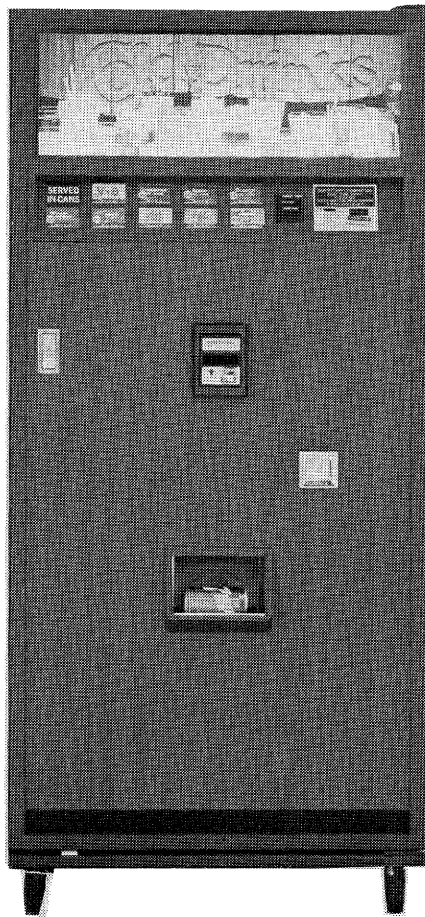

**MODEL 2087E**  
**SERVICE MANUAL**

**Part Number 20839**

REV. JUNE, 1988

## TABLE OF CONTENTS

INTRODUCTION.....	1
SPECIFICATIONS.....	1
INSTALLATION INSTRUCTIONS.....	2-5
Unpack.....	2-3
Loading Instructions.....	3
Price Setting Instructions .....	3
Free Vend.....	4
Price Labels.....	4
Installation Check List.....	5
FEATURES AND FUNCTIONS .....	5-7
Power Switch.....	5
Coin Changer.....	5
12 oz. Ejector Mechanism Assembly .....	5-6
Yoke Assembly.....	6
Cam Escapement.....	6
Vend Complete Switch.....	6
Anti-Theft Bar.....	6
Sold-Out Switch.....	6
Coin Insert Assembly.....	6
Coin Return Lever .....	7
Coin Entrance Slot.....	7
Delivery Door.....	7
Locking T-Handle.....	7
Door Switch.....	7
CONTROL BOARD.....	8-10
Force Vend Switch.....	9
Self Diagnostics.....	9
Digital Read-Out.....	9
ADJUSTMENTS.....	10-11
To Convert from 12 Oz to 10 Oz Cans.....	10
6 Oz Can Adjustments.....	10
Revisions to Full Stroke Switch & Yoke Assembly.....	10
Vend Complete Switch.....	11
REFRIGERATION SYSTEM.....	12-14
Cold Control Setting.....	14
CARE AND CLEANING.....	14
WIRING DIAGRAM .....	15
TROUBLESHOOTING.....	16-19
PARTS ORDERING PROCEDURE.....	20

## **INTRODUCTION:**

This Service Manual contains installation and service information on the CD 5/4 E/C Model Cold Drink Vendor and associated optional equipment and accessories.

CD 5/4 E/C is a nine (9) select Vendor which vends five (5) selections of 12 or 10 ounce cans with four (4) solenoid operated sections of 6 ounce cans only on the inner door.

This model utilizes the "First-in", "First-out" vend principles on all selections. The Electronic Control System on this machine provides the versatility to allow for individual pricing from \$.00 to \$6.35 and parallel vending circuits to eliminate any problem of the entire machine being inoperative. This machine has an Electronic Credit Display which not only shows the customer his accrued credits, but also informs the service person when a selection is out of service.

The CD 5/4 E/C is equipped with control board connections and knock-out plates for currency validators.

## **SPECIFICATIONS:**

### **SPECIFICATIONS**

68" High  
33" Wide  
31 1/2" Deep

### **ELECTRICAL**

115 Volts  
60 Hertz  
10.5 Amps

### **COINAGE**

Mars TR6000 Coin Mechanism  
Coinco C-300 Coin Mechanism  
Coinco 9300L Coin Mechanism

### **CONFIGURATION**

WEIGHT	513 Pounds
SELECTIONS	Five - 12 oz. Cans Four - 6 oz. Cans
CAPACITY	250 - 12 oz. Cans 60 - 6 oz. Cans

## **INSTALLATION INSTRUCTIONS:**

This machine was thoroughly inspected before leaving the Factory, and the Carrier has accepted this Vendor as their responsibility. Any damage or irregularities should be noted at the time of delivery and immediately reported to the delivering carrier. Request a written Inspection Report from the Claims Inspector to file any freight claims for damage. File claim with CARRIER, (NOT THE MANUFACTURER) within 15 days after receipt of the machine.

Record the Model Number and Serial Number on the Vendor and refer to these numbers on all inquiries and correspondence pertaining to that Vendor.

Carefully remove the shipping carton and inspect the machine for concealed damage. Report any damage hidden by the shipping carton direct to the delivering carrier on a "Hidden Damage Report".

Remove the knock-away supports by inserting a screwdriver and splitting the knock-away in two. (See illustration 1) Turn the leveling screws in as far as possible. Position the Vendor in its place of operation. LEAVE AT LEAST SIX (6) INCHES OF SPACE BEHIND VENDOR FOR PROPER AIR CIRCULATION. Level Vendor, making sure all levelers are touching the floor. The Vendor MUST be level for proper operation and acceptance of coins through the Coin Mechanism.

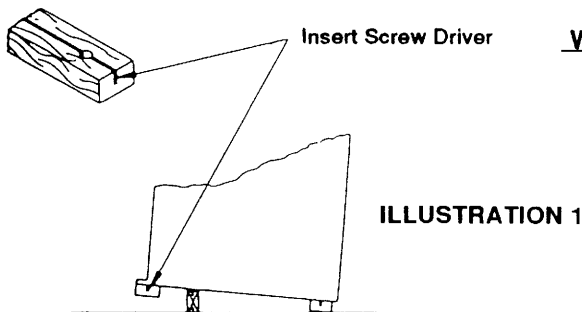

**WARNING:** Do Not block the ventilating screens in front or in the rear of the Vendor. Always allow free ventilation behind a Bank Installation, so that exhaust air is not trapped. Failure to do so could result in a REFRIGERATION FAILURE.

## **UNPACKING:**

Remove the knock-away supports by inserting a screwdriver and splitting the knock-away in two. (See illustration 1) Turn the leveling screws in as far as possible. Position the Vendor in its place of operation. LEAVE AT LEAST SIX (6) INCHES OF SPACE BEHIND VENDOR FOR PROPER AIR CIRCULATION. Level Vendor, making sure all levelers are touching the floor. The Vendor MUST be level for proper operation and acceptance of coins through the Coin Mechanism.

Run the Power Cord through the hole in the back of the cabinet and secure the power cord with the grommet by placing the grommet in the hole provided in the back of the cabinet.

Locate the Vendor within four (4) feet of a 115 Volt power source, with at least six (6) inches of air space between the back of the machine and any wall or obstruction.

To insure safe operation of an electrically equipped Vendor, the Vendor must be grounded. To verify that the receptacle is properly grounded, connect one probe of a test light or meter to the screw holding the receptacle cover. Insert the other probe into each opening of the outlet. If the test does not light when placed in either side of the receptacle, the receptacle is not grounded. (See Illustration 2)

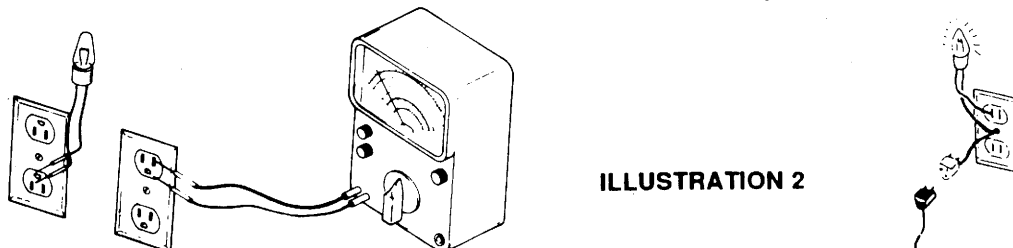

**RECEPTACLE WITH THREE (3) FEMALE OPENINGS:** To verify that the receptacle is properly grounded and polarized, insert one probe of a volt-meter (set to check AC line voltage) or test light, in the ground terminal "hole" of the 3-position receptacle, insert the other probe (of meter or test light) in the L.H. slot (if ground hole is "up") or in the R.H. slot (if ground hole is "down"). You should read 115 VAC on the volt-meter, or the light. (See Illustration 2).

If you find that the receptacle is not grounded, or polarized you should contact a licensed electrician to correctly polarize and/or ground the receptacle to insure safe operation. Consult Local, State, and Federal codes for compliance before installation of the Vendor.

If the receptacle is grounded, but is not the three-prong type the adapter may be used. Attach the wire to a ground or the receptacle cover securing screw. (See Illustration 2)

The Vendor requires a 115 volt/60 Cycle, 20 AMP Electrical Power Source. As the Vendor is plugged in, the following should occur.

1. The Display Light will come on.
2. The Correct Change Circuit should be activated. If a Coinco Coin Changer is used, the "Correct Change" light will come on. (With a Mars Changer, this light will not illuminate until a selection is made)
3. The "Make Another Selection" light will come on.
4. The Evaporator Motors and Refrigeration unit will run.
5. A "period" or decimal point will appear in the Credit Display.

### **LOADING INSTRUCTIONS:**

CD 5/4 E/C The selections are numbered right to left on the back of inner door, and then left to right on the columns inside the cabinet. Selections 2-1 through 2-4 (See Self Diagnostics section of the Controller operation) are on the Inner Door and are for 6 ounce cans. Selections 1-1 through 1-5 are inside the Vendor and are for 12 ounce cans. The 12 ounce compartments will hold approximately 50 cans each and the 6 ounce compartments will hold approximately 15 cans each

### **PRICE SETTING INSTRUCTIONS:**

All vend prices are controlled by the Controller and a vend price must be established for each selection. When the outer door is opened and the Door Switch is released, the Controller will automatically be placed in the Service Mode. Before any input to the Controller, the service person should note and record any information other than "period" or decimal point displayed on the Digital Read-Out. This indicates that a failure has been recorded by the Controller. Once the Controller has been cleared, these failures must be repeated before the Controller will record and display again. (See Self Diagnostics section of Controller Operation)

To reprogram or change vend prices, operate the PRICE SWITCH located on the Controller Board. The Controller is now in the "Programming Mode". (See Page 8 Illustration 6). Depressing a Selection Button once displays the present vend price for that selected product in the Credit Display.

Releasing and depressing the SAME selection button a second time INCREASES the vend price in \$.05 increments at the rate of \$.05 every half second. Continued depressing of the selection button alternates between increasing and decreasing the vend price of that selection

When the desired vend price for the selection appears in the Digital Read-Out, the price for that selection is set.

When establishing vend prices, make sure the product corresponds with the vend price and the "Vend Price Label" agrees with the price programmed into the Controller. Check the "Product Labels" to be sure that it coincides with the product loaded in the vend column.

When the price setting procedure is complete, the Controller will automatically exit from the "Programming Mode" when the outer door is closed. Test vend each selection that has been programmed into the Controller to insure that the price setting procedures have been followed and that the Controller has been properly programmed.

**FREE VEND:**

Setting the vend price at \$.00 will set that particular selection at "Free Vend" and no money is required to dispense that product when the machine is in the normal Vend Mode with the door closed.

The following is a step by step procedure and illustration for establishing vend prices dor CD54/EC Model Cold Drink Vendors: (See Illustration 3)

PRICE SETTING INSTRUCTIONS				
ENTER SERVICE MODE: (OPERATE PRICE ARMING SWITCH)				
TO INCREASE VEND PRICE				
				
<p><b>Step #1</b> PUSH and HOLD Selection Button - current vend price is displayed.</p>	<p><b>Step #2</b> Release Button for 1 second.</p>	<p><b>Step #3</b> PUSH and HOLD the Button again. The Vend Price will increase in 5c increments.</p>	<p><b>Step #4</b> Release Button when price is displayed. Setting is complete for that selection.</p>	
TO DECREASE VEND PRICE				
				
<p><b>Step #1</b> PUSH and HOLD Selection Button - current vend price is displayed.</p>	<p><b>Step #2</b> Release Button for 1 second.</p>	<p><b>Step #3</b> PUSH and HOLD the Button again. The Vend Price will increase - release the Button for 1 second.</p>	<p><b>Step #4</b> PUSH and HOLD the Button again. The Vend Price will decrease in 5c increments.</p>	<p><b>Step #5</b> Release Button when desired price is displayed. Price setting is complete for that selection.</p>

ILLUSTRATION 3

**PRICE LABELS:**

The price stickers should be put on the product labels as shown. With the price labels in place the product labels should be put in place behind the proper "Push Button". (See Illustration 4)

**IMPORTANT:** After loading, make sure that the Vend Price is correct for each selection, and that the Vend Price, and the Product Labels correspond for each selection.

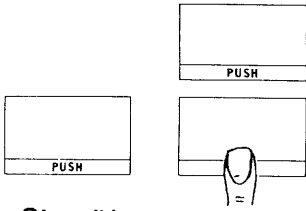
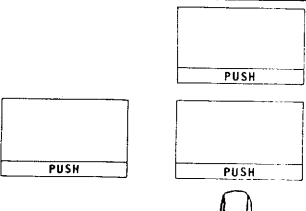
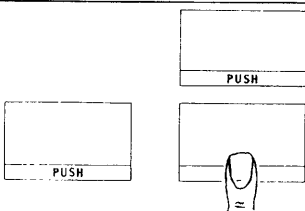
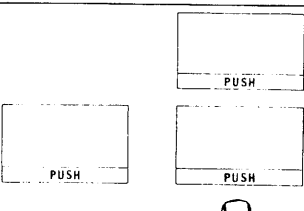
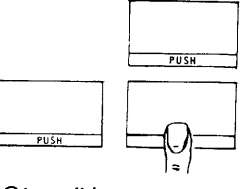
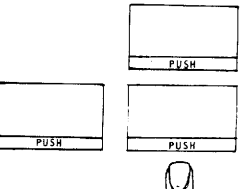
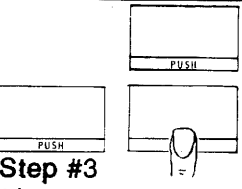
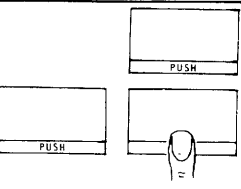
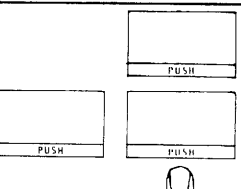
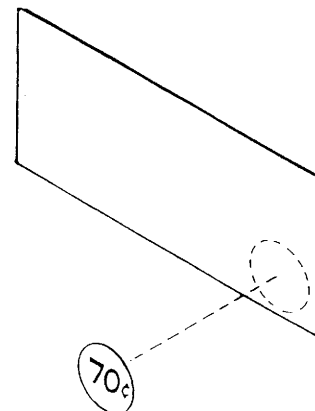

ILLUSTRATION 4

## **INSTALLATION CHECK LIST:**

1. All Shipping brackets, packing material, and tape have been removed.
2. Vendor is properly located for access to power source outlet and Vendor is level.
3. All components are installed on Vendor and are in good condition.
4. Service Cord plug-in receptacle is grounded or ground adapter has been installed.
5. Coin Mechanism adjustments have been made, if necessary, and vend prices are properly set.
6. Vendor has been properly loaded and all items in each selection correspond to the Vend Price and Product Labels.

**WARNING:** This Vendor is equipped with a 5 amp Circuit Breaker to Protect the Vend Circuit only. The Refrigeration System is not on the breaker.

## **FEATURES AND FUNCTIONS:**

### **POWER SWITCH:**

The Power Switch is located in the lower right inside cabinet compartment, and has been incorporated for the protection of the Electronic components. This switch should be placed on the "OFF" position before disconnecting or removing any electronic components. This Switch is a manually operated Toggle Switch and MUST be placed in the "ON" position during the normal operation or if power is needed to the vend circuit during servicing.

### **COIN CHANGER:**

The changers used in this model must be "Control Board directed" or "dumb" changers such as the Mars TRC6000 or the Coinco C-300 and 9300L. Receptables are provided for these type changers and are located just below the display area to the right of the Control Board. When a Mars TRC6000 or Coinco 9300L changer is used, the Coin Inventory Switches on the Control Board must be used to remove coins from the payout tubes. (See Illustration 6, Page8)

### **12 OZ. EJECTOR MECHANISM ASSEMBLY:**

There are a total of five (5) 12 ounce Ejectors, one located below each product column. This is the Vend Mechanism, which dispenses the product. After proper credit has been accumulated and a selection switch is depressed, the Controller will direct a signal to the Vend Mechanism to start the vending procedure. The following defines the components of the Ejector Mechanism, along with their functional operation. (Refer to Illustration 12 for component identification.)

**NOTE:** Be sure the Ejector Mechanism is clean and free of foreign matter and that all parts move freely. The product must roll to the delivery area.

## **12 OZ. EJECTOR MECHANISM ASSEMBLY: (CONTINUED)**

### **VEND SOLENOID:**

The Vend Solenoid energizes when the signal is received from the Controller Board. As the solenoid energizes, it moves the Yoke Assembly and the Cam Escapements, releasing the product, allowing it to roll to the delivery area. The movement of the solenoid also operates the Vend Complete Switch to reset the Controller.

### **YOKE ASSEMBLY:**

The Yoke Assembly, when operated by the Vend Solenoid, operates the Cam Escapements, releasing the product in the vend area, allowing it to roll to the delivery area. The trailing edge of the Yoke Assembly moves upward to hold the second can during the vend cycle. The Vend Complete Switch is also operated by the Yoke Assembly, and when in the stand-by position, must hold the switch activated. (N.O. position)

### **CAM ESCAPEMENTS:**

The Cam Escapements, when operated by the Yoke Assembly, releases the can in the vend area, allowing it to roll to the delivery area. When at stand-by, the escapements retain the product in the vend position.

### **VEND COMPLETE SWITCH:**

The Vend Complete Switch, when released by the action of the Yoke Assembly, sends a signal to the Control Board to "shut-off" the Vend Solenoid. At stand-by this switch must be held in the activated (N.O.) position by the Yoke Assembly.

### **ANTI-THEFT BAR:**

The Anti-Theft Bar prevents the cam escapements from being moved while the Vend Solenoid is de-energized.

### **SOLD-OUT SWITCH:**

The Sold-Out Switch is activated by the can in the vend position. If no cans are present, this switch will deactivate (N.C.) and light the sold-out indicator in the digital display when the selection button is depressed.

### **COIN INSERT ASSEMBLY:**

Located on the outside of the door in the Selection Panel, contains the "To Operate" decal, coin return lever, and coin entrance slot.



### **COIN RETURN LEVER:**

If a bent coin or foreign material lodges in the coin mechanism acceptor, the coin return lever, by pressing down on the lever will open the acceptor in an attempt to clear the lodged material. The coins will be returned to the Coin Return Cup located in the lower panel of the door.

### **COIN ENTRANCE SLOT:**

This slot directs the coins deposited through the plastic chute to the coin mechanism to establish credit. The plastic chute should align properly with the entrance of the coin mechanism.

### **DELIVERY DOOR:**

The delivery door is located in the main door, lower center. This door allows the product to be taken out of the Vendor after a vend has been made. The delivery door also provides a sealing function for the refrigerated cabinet. If the delivery door does not close properly it could contribute to a condensation build-up in the cabinet area.

### **LOCKING T-HANDLE:**

The locking T-handle is used to open the main door. Incorporated into this handle is a cylinder lock and a securing bolt.

**NOTE:** THE KEYS FOR THIS LOCK WILL BE TAPED TO THE INSIDE OF THE COIN RETURN CUP.

Inserting the key into the Cylinder lock and turning, will allow the T-handle to "pop open". By turning the T-handle counter-clockwise will open the main door.

To close and lock the main door, close the main door against the cabinet, while applying pressure, turn the T-handle clockwise until door is snug. Push in on the "T" Handle to lock the Vendor.

**CAUTION:** DO NOT OVER TIGHTEN T-HANDLE. THIS COULD DAMAGE LOCKING PARTS.

### **DOOR SWITCH:** (See Illustration 5)

The Door Switch is mounted on the outer door and when the door is closed the Controller is placed in the "Vend Mode" or operational mode. On the initial closure of the door the Controller will scan the vending circuit and if an "open" Solenoid Switch is detected, the Controller will activate that particular solenoid in an attempt to correct the "open" circuit. If the Solenoid switch does not return to its normal stand-by position (N.O.) that selection will be determined defective and when attempted to vend, the "MAKE ANOTHER SELECTION" light will be illuminated and no product will be dispensed.

When the outer door is opened, releasing the Door Switch, the Controller is automatically placed in the Service Mode. Pulling out on the Switch plunger with the door opened will place the machine in the "Vend Mode" while servicing.

POWER SWITCH

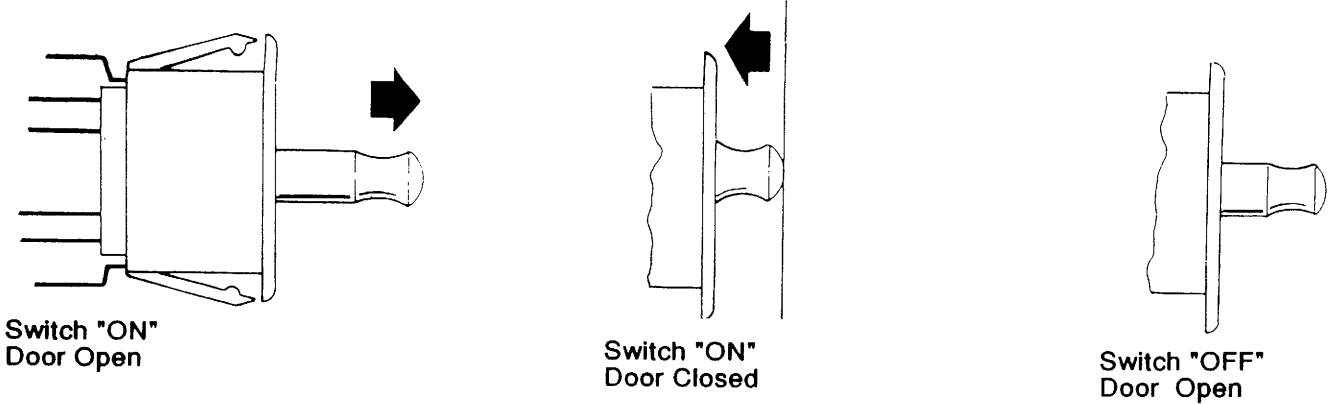

Switch "ON"  
Door Open

Switch "ON"  
Door Closed

Switch "OFF"  
Door Open

ILLUSTRATION 5

**CONTROL BOARD:**

The Controller is the central control for the entire vending function and circuits of the machines. It audits input from the Coin Changers and directs functions to the Changer and Read-Out, records failures and controls all selections, prices, and vending functions.

When the outer door is opened, releasing the Door Switch, the Controller will display to the service person any failures that may have been detected. The faulty selection number will be displayed on the Digital Read-Out. If more than one faulty selection has been detected, the Controller will alternate between these selections. The display will continuously show the selection numbers for each selection that has been recorded for 2 seconds each. (See Self Diagnostics - Page 9)

The Controller will sense the highest vend price that has been programmed for each selection and when credit is equal to the highest vend price, the "coin accept circuit" will be broken, and no additional credit can be established. Coins inserted, when in this condition, will be automatically returned to the customer.

**NOTE:** When a Coinco C-300 Coin Changer is used, the 5c, 10c, & 25c Switches will not be used. These switches will be located on the Coin Changer.

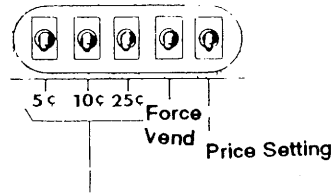

CHANGER  
INVENTORY SWITCHES

ILLUSTRATION 6

The present Controller is designed to operate with Solenoid operated vend mechanisms. The "Vend Mechanism" Control Switches are located on the Control Board, just to the left of the Program Switches and MUST be positioned to the "UP" or "ON" position. The sketch below indicated the required position for the Control Switches. THESE SWITCHES ARE PROPERLY SET WHEN THE MACHINE LEAVES THE FACTORY. (See Illustration 7)

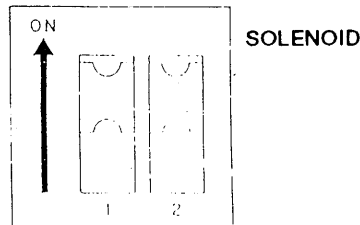

ILLUSTRATION 7

## FORCE VEND SWITCH:

A "Force Vend" Switch is provided on the Control Board which can only be accessed when the door is open. This switch is used to prohibit using the Vendor as a "Dollar Bill Changer" and not making a vend.

**FORCE VEND ON** - In the "ON" (left) position, when Dollar Bills are inserted as part of the purchase price, this switch disables the coin return circuit, which "forces" the customer to purchase an item. When in "Force Vend On" this switch does not affect coin return of change inserted.

**FORCE VEND OFF** - When in the "OFF" (right) position, the coin return circuit remains activated, allowing change to be returned for the dollar bill credit.

## SELF DIAGNOSTICS:

When the outer door is opened the Digital Read-Out will display the selection number of any selection determined inoperative. If more than one faulty selection has been detected, the Digital Read-Out will alternate between these selections. The display will show the selection numbers for each defective selection for two seconds each. (See Illustration 8) These failures should be recorded before any input or re-programming of the Controller is made. Closing the outer door or activating the door switch will remove this information from the memory and the failures must be repeated before the Controller will display this information again.

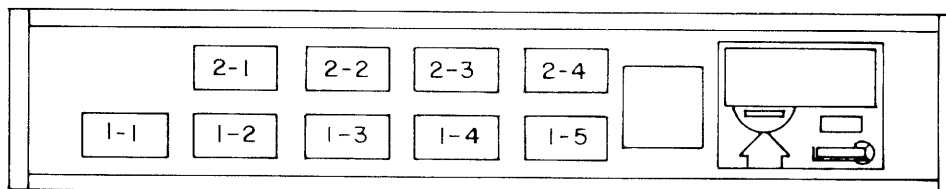

ILLUSTRATION 8

The above numbers will be displayed in the Digital Read-Out if any failures are detected pertaining to that particular selection

NOTE: Selections 1-6, 1-7, and 2-5 are not used in the 9 Selection Combo and will be displayed each time the Service Mode is entered.

## DIGITAL READ-OUT:

In the display the amount of money deposited for each vend will be shown to the customer. In the event the Coin Changer cannot make change, the "USE CORRECT CHANGE" indicator will flash 10 times in a 10 second interval. The inserted coins will be returned when the Coin Return Lever is operated. The amount returned will be displayed for 2.5 seconds.

If a Selection Button is depressed for a product from a column that is either sold-out or has been determined defective, the "MAKE ANOTHER SELECTION" indicator will flash 10 times in a 10 second interval. If all columns are empty the "MAKE ANOTHER SELECTION" indicator will be left on continuously and no further money will be accepted.

In the event a Selection Button is pressed with insufficient credit for that selection, the "CHECK SELECTION PRICE" indicator will flash 10 times in a 10 second interval. Additional coins can be inserted to establish correct credit, or the Coin Return Lever operated and credit will be returned.

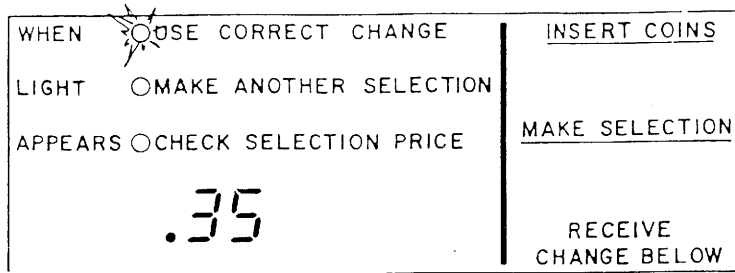

ILLUSTRATION 9

## **ADJUSTMENTS:**

### **TO CONVERT FROM 12 OZ. TO 10 OZ. CANS:**

Each 12 ounce selection can be changed individually, for either 12 ounce or 10 ounce cans.

For each selection you wish to vend 10 ounce cans, remove the (2) sheet metal screws from that Can Jump Guard. Lower the front of the Can Jump Guard, and replace the (2) metal screws, making sure they go below that Cross Rod. (See Illustration 10)

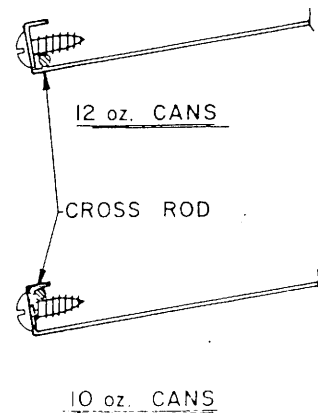

ILLUSTRATION 10

### **6 OZ. CAN ADJUSTMENTS:**

It may be necessary to adjust the 6 ounce Ejector Mechanism to vend various diameter of cans. The adjustments are made by turning the two (2) screws that provide the stop for the Drop Plate. Turning the screws clockwise reduces the size of the opening through which the can must fall.

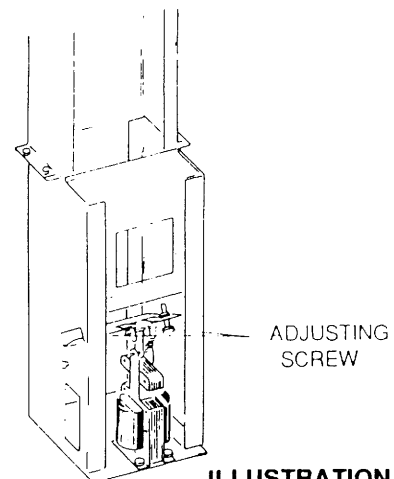

ILLUSTRATION 11

### **REVISIONS TO FULL STROKE SWITCH AND YOKE ASSEMBLY:**

To obtain a more positive action on the Vend Complete Switch, the design of the Yoke Assembly and the Switch Actuator has been changed where-by the Switch Actuator is carried through the stroke of the Vend Solenoid. If the Full Stroke Switch does not operate properly, the C.R.E.M. circuit to the Coin Mechanism will not be completed, then the credit will not be cancelled when the vend cycle is complete, or the coin mechanism will not accept coins for the next vend.

## VEND COMPLETE SWITCH - (FUNCTIONS AND ADJUSTMENTS)

1. The Switch will cancel credit to the Controller Board, if out of adjustment, possible double vending could occur.
2. The Switch also assures a "Full Stroke" to the Vend Solenoid, if out of adjustment, a short pulse or "half" vend could occur.
  - a. Switch should "click" within the first 3/16" travel of the Vend Solenoid.
  - b. Switch may be adjusted by bending up or down on the actuator as needed.
  - c. If Switch fails to operate on the "up-stroke" of the Vend Solenoid, and is not held double vending could occur.
  - d. If Switch fails to operate on the "down-stroke" of the Vend Solenoid, and is not held actuated (N.O.) at stand-by, the Controller will determine that selection defective a vend is attempted and not product will be dispensed.

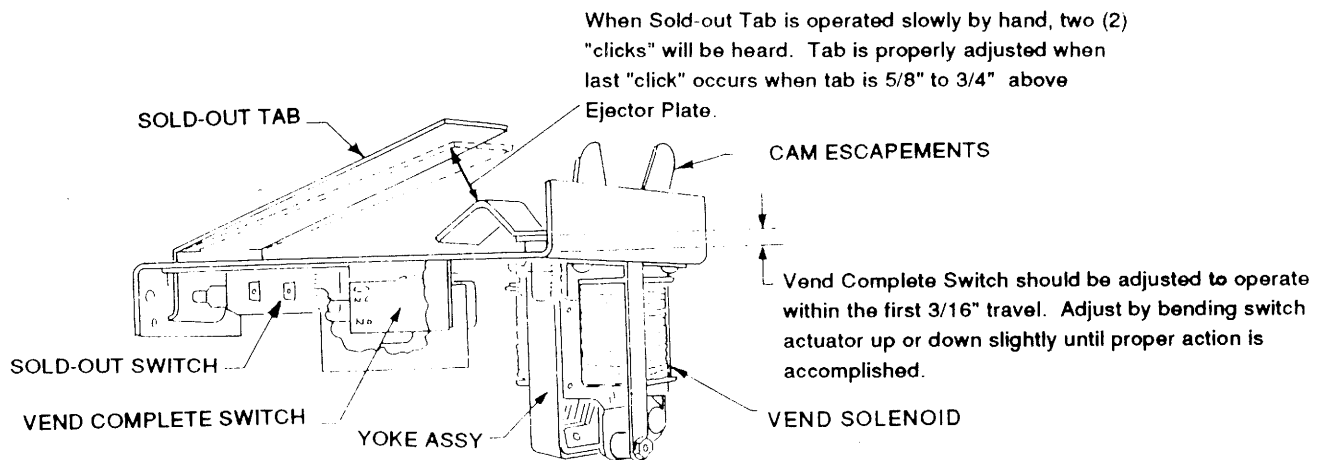

ILLUSTRATION 12

## **REFRIGERATION SYSTEM:**

The Refrigeration System is a sealed unit. The system is mounted to the base of the Vendor and in the base of the insulated cabinet. The Refrigeration System consists of the following:

### **1. COMPRESSOR AND SEALED SYSTEM**

This system consists of a Compressor, Evaporator, Condensor, Dryer, and all copper tubing connecting the components. Do not puncture or break sealed system without prior authorization from the Factory Service Department.

### **2. CONDENSOR FAN AND MOTOR**

Located between the Compressor and Condensing Unit. The function of this fan and motor is to draw air thru the condensor coil, cooling the cases, and move air across the Compressor to cool the unit.

### **3. EVAPORATOR FAN AND MOTOR**

Located on top of the evaporator coils, in the insulated cabinet, it's function is to draw air thru the coil and circulate this air around the insulated cabinet. These fan motors will be running all of the time the unit is plugged into electricity.

### **4. COLD CONTROL**

The Cold Controls, located on the left side wall of the insulated cabinet, function is to sense the internal temperature of this cabinet and switch the Compressor unit "ON" and "OFF" when the desired temperature is reached. On this control is a dial face with numbers. By turning the control knob to a higher number will allow the cabinet to get colder. Turning this knob to a lower number will make the insulated cabinet warmer.

### **5. OVERLOAD PROTECTOR**

The function of the Overload Protector is to sense the external temperature of the Compressor. If the Compressor gets too hot the Overload Protector will interrupt the electric circuit to the Compressor.

### **6. STARTING RELAYS**

The Starting Relay function is to switch the electrical circuit in the Compressor from the start-up winding to the main run winding in the unit.

Know and understand the refrigeration units and how they operate. Units may vary, but the operation is basically the same. Never guess at the problem; solve it by reading the symptoms.

#### **I. COMPRESSOR WILL NOT START**

##### **A. Voltage (check to see if Compressor has power)**

1. Tripped breaker or blown fuse.
2. Wall outlet faulty.
3. Short or tear in power cord.
4. Faulty Cold Control .
  - a. Unplug power supply, remove screws from thermostat. Use a Jumper wire, or place screw through terminals; restore power and check to see if unit runs.
5. Check improper wiring.

#### **II. COMPRESSOR TRIPS ON OVERLOAD**

- A. Improper Voltage (117 AC normal) 5-10% above, 5% below.
- B. Overload defective. (See VII, B)
- C. Relay defective. (See VII, C)
- D. Compressor defective. (See VII, D)
- E. Start capacitor defective. (See VII, E)
- F. Short in other components. Isolate and eliminate each electrical component until short is found.
- G. Compressor is too hot.
  1. Dirty Condensor.
  2. Faulty Condensor motor or blade.
  3. Restricted air flow.

### III. NOISY OR VIBRATING UNIT

- A. Components rubbing or touching each other.
  - 1. Check fan blades and motors.
  - 2. Loose shrouds and harness.
  - 3. Copper tubing.
  - 4. Loose or unsecured parts.
- B. Grommets.
  - 1. Worn, aged.
- C. Compressor.
  - 1. Bad valves.
  - 2. Slugging.
  - 3. Bad windings.
- D. Relay.
  - 1. Frozen in start position.
- E. Low voltage.

### IV. UNIT SHORT CYCLES

- A. Cold Control.
- B. Air flow restricted.

### V. UNIT OPERATES LONG OR CONTINUOUSLY

- A. Thermostat faulty.
- B. Air flow restricted.

### VI. REFRIGERATED SPACE TOO WARM

- A. Restricted evaporator air space.
  - 1. Evaporator motor or blades bad. Evaporator will usually be iced over insulating evaporator.
  - 2. Condenser air flow restricted.
    - a. Plugged or dirty Condenser.
    - b. Condenser motor or blade bad.
    - c. Blade stuck.

### VII. TROUBLE SHOOTING UNIT CIRCUITS USING OHM-VOLT METER

- A. Using volt meter, check power source.
- B. Check overload. (Note: Power must be off and fan circuit open)
  - 1. Using Ohm meter check terminals 1 & 3 for continuity. If no continuity, overload may be tripped. Wait 10 minutes and try again. If still no continuity, overload is defective; replace.
- C. Check Relay: See Schematic (Illustration 13)
  - 1. Pull lead terminals or relay off the Compressor depending upon which type of relay is used. (Note: Keep relay energized)
  - 2. Check terminals 1 & S or L & S, Replace relay if there is continuity.
  - 3. Check terminals 1 & M or L & M, Replace relay if there is no continuity.
- D. Checking Compressor: See following schematic.
- E. Checking Capacitor:
  - 1. Short across the Capacitor leads and observe spark.
  - 2. Check relay terminal 1 & L with OHM Meter, if there is continuity, replace Capacitor.

## REFRIGERATION SYSTEM: (CONTINUED)

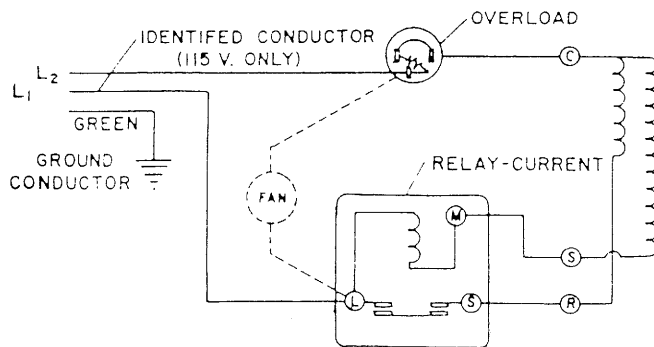
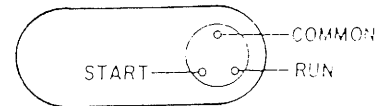

ILLUSTRATION 13

**NO CAPACITOR**  
 Approximate Resistance  
 Reading Across Terminals  
USE RXI SCALE  
 COMMON - Start 12 Ohms  
 COMMON - Run 2 Ohms  
 RUN - Start 14 Ohms  
 COMMON - Shell No  
 Continuity



## COLD CONTROL SETTING:

These recommended Cold Control Settings are based on an average temperature outside the cabinet to supply the maximum cooling for inside products.

COLD CONTROL SETTING	AVERAGE ROOM TEMPERATURE
1	
2	80°F to 110°F
3	65°F to 85°F.
4	
5	
6	

ILLUSTRATION 14

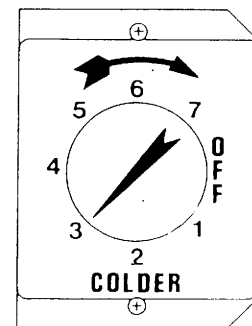

## CARE AND CLEANING:

### CABINET EXTERIOR:

Wash with a mild detergent and water, rinse and dry thoroughly. Wax occasionally with a quality car wax. Plastic exterior parts may be cleaned with a quality plastic cleaner.

### CABINET INTERIOR:

Wash with a mild detergent and water. Odors may be eliminated by including baking soda or ammonia in the cleaning solution. Remove and clean Drain Hose to eliminate any deposits that may restrict condensate water flow.

The Vend Mechanisms **MUST** be kept clean. Any build-up of syrup deposits can cause these mechanisms to malfunction. Use soap and water with great care so as not to get water into the electrical components.

## REFRIGERATION SYSTEM:

Clean dust from Condenser and Screen in the front door with a soft bristle brush or a vacuum cleaner. Remove any dirt or debris from the Refrigeration System Compartment. Remove and clean the Condensation Pan.

**CAUTION:** Always Disconnect Power Source before cleaning.



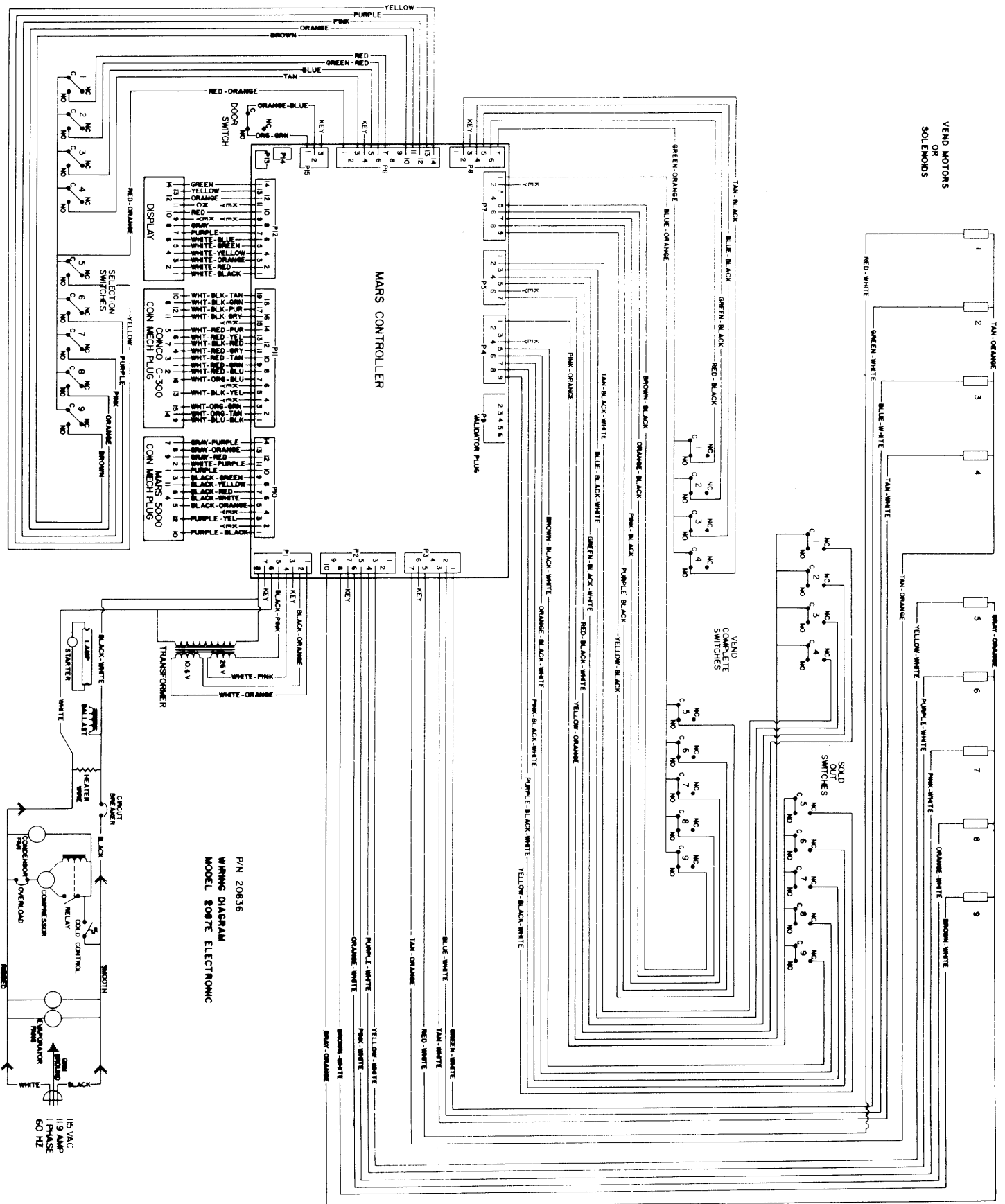

# TROUBLE SHOOTING:

PROBLEM BASIC VENDOR	CAUSE	CORRECTIVE ACTION.
Vendor rejects all coins - display lamp off.	<p>P1 plug on Controller unplugged or loose.</p> <p>Transformer Assembly unplugged at Cabinet.</p> <p>Black and white wires unplugged at Refrigeration System.</p> <p>Circuit breaker in Vendor tripped or broken.</p> <p>Damaged or defective power cord.</p> <p>Vendor unplugged.</p> <p>Fuse or circuit breaker tripped in supply (building) outlet.</p>	<p>Check the wire connections at both ends of wire harness for good connections.</p> <p>Check the wire connections at both ends of wire harness for good connections.</p> <p>Check the wire connections at both ends of wire harness for good connections.</p> <p>Reset or replace circuit breaker.</p> <p>Repair or replace power cord.</p> <p>Plug Vendor in.</p> <p>Reset or replace.</p>
Vendor rejects all coins - display lamp on.	<p>P1 plug on Controller unplugged or loose .</p> <p>Do not have 110 volts between black/white wire and white wire on P1 plug on Controller (unplug P1 plug before checking)</p> <p>Door Switch defective or in a broken circuit.</p> <p>P15 plug on Controller unplugged or loose.</p> <p>P10 plug on Controller loose or unplugged. (Mars only)</p> <p>The purple/black, purple/yellow, or black/red wires between P10 plug on Controller and the Mars Coin Mech plug loose or broken.</p>	<p>Check the wire connections at both ends of the wire harness for good connections.</p> <p>Use volt meter to check voltage between the two wires. Check the wire connections at both ends for good connections.</p> <p>Check the Door Switch for any breakage and for good wire connections.</p> <p>Check the wire connections at both ends of wire harness for good connections.</p> <p>Check the wire connections at both ends of wire harness for good connections.</p> <p>Check the wire connections at both ends of wire harness for good connections.</p>

# TROUBLE SHOOTING:

PROBLEM BASIC VENDOR	CAUSE	CORRECTIVE ACTION.
Vendor rejects all coins - display lamp on (Continued)	<p>P11 plug on Controller loose or unplugged. (Coinco Coinage Only)</p> <p>White/red/green and white/red/tan wires between P11 plug on Controller and Coin-co Coin Mech. Plug loose or broken.</p> <p>Bad Coin Mechanism.</p> <p>Bad Controller Board.</p>	<p>Check the wire connections at both ends of wire harness for good connections.</p> <p>Check wire connections at both ends of wire harness for good connections.</p> <p>Repair or replace Coin Mechanism.</p> <p>Replace Controller Board.</p>
Vendor accepts coins, but does not vend on any selections.	<p>P6 plug on Controller loose or unplugged.</p> <p>Broken red/orange wire between P6 plug on Controller and #1 Selection Switch.</p> <p>Vend Prices set wrong.</p> <p>Bad Controller Board</p>	<p>Check wire connections at both ends of wire harness for good connections.</p> <p>Check wire connections at both ends of harness for good connections.</p> <p>Set prices correctly.</p> <p>Replace Controller Board.</p>
Vendor accepts coins, but does not vend on one or more selections.	<p>Any of the following Controller Board connections are loose or unplugged: P2, P3, P4, P5, P7, P8.</p> <p>A broken or loose wire from Controller to Selection Switch, Sold Out Switch, or Solenoid</p> <p>A Sold Out Switch or Vend Switch defective or out of adjustment.</p> <p>Vend prices set wrong.</p> <p>Bad Controller Board</p>	<p>Check wire connections at both ends of wire harness for good connections.</p> <p>Check wire connections at both ends of wire harness for good connections.</p> <p>Re-adjust or replace switch.</p> <p>Set prices correctly.</p> <p>Replace Controller Board.</p>

## TROUBLE SHOOTING:

PROBLEM BASIC VENDOR	CAUSE	CORRECTIVE ACTION.
Vendor vends properly, but pays out wrong change or no change at all.	<p>Vend prices set incorrectly.</p> <p>Changer out of change.</p> <p>Defective Coin Mechanism.</p> <p>Bad Controller Board.</p> <p>Product loaded wrong.</p>	<p>Set vend prices properly.</p> <p>Fill changer inventory tubes.</p> <p>Repair or replace Coin Mechanism.</p> <p>Replace Controller Board.</p> <p>Load product properly.</p>
Product does not match selection pushed.	<p>Vend Mechanism plugs crossed.</p> <p>Bad Controller Board.</p>	<p>Make sure vend mechanisms are plugged in correctly.</p> <p>Replace Controller Board.</p>
Vendor free vends.	<p>Vend Switch defective or out of adjustment.</p> <p>Bad Coin Mechanism.</p> <p>Bad Controller Board.</p>	<p>Re-adjust or replace switch.</p> <p>Replace or repair Coin Mechanism.</p> <p>Replace Controller Board.</p>
Cannot enter service mode.	<p>Door Switch defective or in a broken circuit.</p> <p>P15 plug on Controller is loose or unplugged.</p> <p>Bad Controller Board.</p>	<p>Check the Door Switch for any breakage and for good wire connections.</p> <p>Check the wire connections at both ends of the wire harness for good connections.</p> <p>Replace Controller Board.</p>
Can enter service mode, but not all functions operate.	<p>Broken red/orange wire between plug on Controller and the #1 Selection Switch.</p> <p>Broken red/orange wire between Selection Switches</p>	<p>Check wire connections at both ends of the wire harness for good connections.</p> <p>Check wire connections at both ends of the wire for good connections.</p>

PROBLEM BASIC VENDOR	CAUSE	CORRECTIVE ACTION.
<p>Can enter service mode, but not all functions operate. (Continued)</p>	<p>Selector Switch out of adjustment or broken.</p> <p>The following Coin Mech plug connections could be bad; purple/black, purple/yellow, gray/red, gray/orange, gray/purple. (Mars Coinage Only)</p> <p>Bad Coin Mechanism.</p> <p>Defective Controller Board.</p>	<p>Re-adjust or replace Selector Switch .</p> <p>Check wire connections at both ends of wire harness for good connections.</p> <p>Repair or replace Coin Mechanism.</p> <p>Replace Controller Board.</p>
<p>No display, but Vendor operates properly.</p>	<p>Bad wire Connections between Display and P12 plug on Controller.</p> <p>Bad Coin Mechanism.</p> <p>Defective Controller Board.</p>	<p>Check wire connections at both ends of wire harness for good connections.</p> <p>Repair or replace Coin Mechanism.</p> <p>Replace Controller Board.</p>

## **PARTS ORDERING PROCEDURE:**

When ordering parts, include the following information:

1. Shipping address.
2. Address where the invoice should be sent.
3. The number of parts required.
4. Always refer to the pertinent parts and/or service manual for the correct part number and description of a specific part.
  - a. If you do not have the right parts manual at the time you order contact Selectivend, Inc., P.O. Box 488, 165 No. 10th Street, Waukee, Iowa 50263. They will provide a copy for you.  
  
Don't hold the order pending receipt of the parts manual; use the most accurate description you can (and the model number and serial number of the machine) include the name of the assembly in which the part is used and, if practical, a sample part. Furnish any information which will enable our department to pinpoint the exact part needed.
  - b. When "RIGHT" and "LEFT" are used in connection with the name of the part, it is taken to mean that the person is facing the machine.
5. Always include model number and the serial number of the machines for which the parts are needed on the order.
6. List any special shipping instructions.
  - a. Always note on the order if you require air or air special truck, parcel post, or rail. If a specific carrier is desired, note it on the order.
7. Sign the order and note the date entered on the order.
8. When a purchase order number is used, be sure that it is legible and visible.

MAIL YOUR ORDER TO: Selectivend, Inc.  
P.O. Box 488  
165 North 10th Street  
Waukee, Iowa 50263

All orders are carefully packed and inspected prior to shipment. Damage incurred during shipment should be reported at once and a claim filed with the terminating carrier.

