

# **SNACK MART III**

## **Refrigerated**

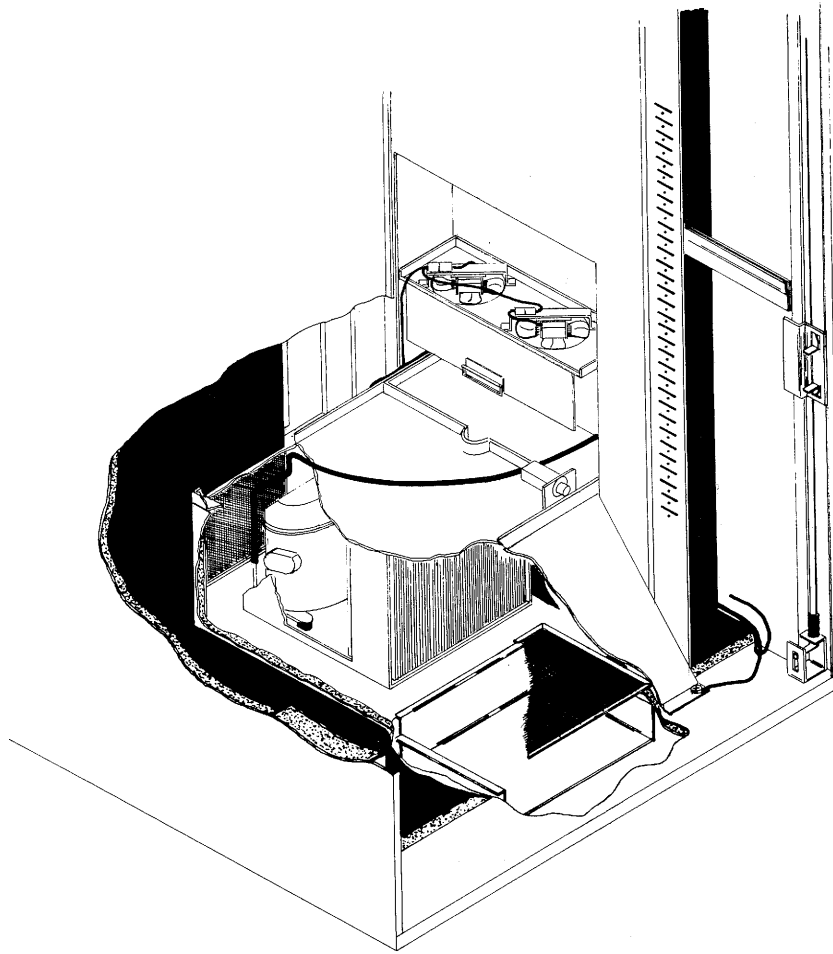

# **SUPPLEMENT SERVICE**

## **MANUAL**

P/N 4201852

**INTRODUCTION:**

The contents of this supplement will contain service and installation information pertaining to the Snack Mart III refrigerated merchandiser.

The refrigerated Snack Mart III is designed to keep candy and pastries fresh and unspoiled in room temperatures up to 100° F. or 37° C. The refrigeration system is capable of maintaining internal cabinet temperatures from 70° F. (21° C.) to 75° F. (24° C.) in room temperatures of 90° F. (33° C.) and above.

The condensing unit is located inside the duct channel on the bottom of the machine.

The evaporator fan is located in the partition panel duct system and circulates air throughout the insulated cabinet.

**SPECIFICATIONS:**

Series	3020	3021	3022
Height	72	72	72
Width	40	40	34-1/4
Depth	36	36	36
Weight			

**ELECTRICAL:**

SERIES 3021	SERIES 3020-3022
Power Requirement: 115 VAC 60 Hz 100 VAC 50 Hz	Power Requirements: 220 V - 50 Hz - 1 PH 240 V - 50 Hz - 1 PH
Operating Amps: 7.2 Amps	Operating Amps: 3.4 Amps @ 220 V.
Locked Rotor 24.0 Amps	Locked Rotor: 11.2 Amps

**REFRIGERATION SYSTEM:**

	Pressure Low Side Room Temperature	PSI
Refrigerant Charge 10 Ounces Freon 12	70° F (21° C)	25
	80° F (27° C)	33
	90° F (32° C)	40

## INSTALLATION INSTRUCTIONS:

To minimize installation time and to avoid service problems due to improper installation, follow the instructions outlined in the Snack Mart III P/N 4201217 Service Manual and any additional information given in the supplement.

## UNPACKING:

Follow the unpacking instructions in the service manual P/N 4201217 in addition to the following.

Located in the bottom of the main cabinet is a cool air inlet duct that must be installed after machine is in place and leveled.

## GROUNDING AND ELECTRICAL:

For proper operation of this electronic controlled piece of equipment, it is recommended that the equipment be connected to a properly-polarized and grounded circuit.

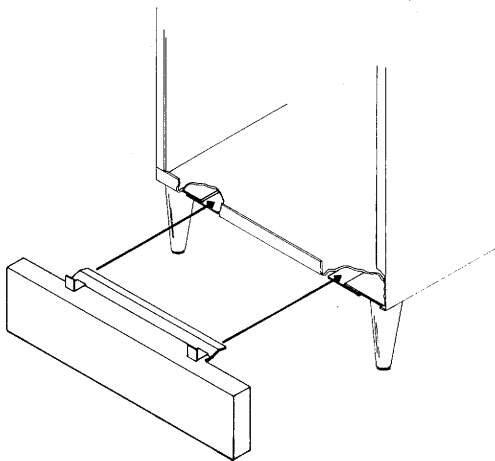

ILLUSTRATION #1

## KICK PANEL (Optional)

Kit Number 1216808-005

The kick panel is installed to cover the front legs of the machine. The kick panel hangs on brackets fastened to the front legs. To install this panel, proceed as follows (see **Illustration #1**):

1. Loosen the two bolts, using a 7/16 wrench, holding the legs to the bottom of machine (see **Illustration #1**).
2. Using the two loosened bolts, position the bracket as shown in illustration and secure with bolts.
3. With bracket secured, slide the kick panel onto the bracket as shown in illustration.

## WARM AIR SCOOP

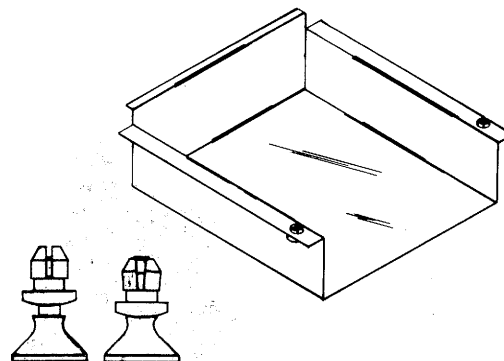

ILLUSTRATION #2

## WARM AIR SCOOP: (See Illustration #2)

The warm air scoop is installed with the air scoop open end facing the front of machine. It is equipped with two (2) grommet fasteners, and a locking flange to secure to bottom of the machine. To install, proceed as follows:

1. Unlock grommets by pulling out on plunger (see illustration).
2. Slide the lock flange up into the opening and back under screen mesh (see illustration).
3. Raise up on front to seat grommets into their position.
4. With grommets seated in the holes, "push in" on the plunger to lock scoop into place.

### REFRIGERATION SYSTEM System Identification

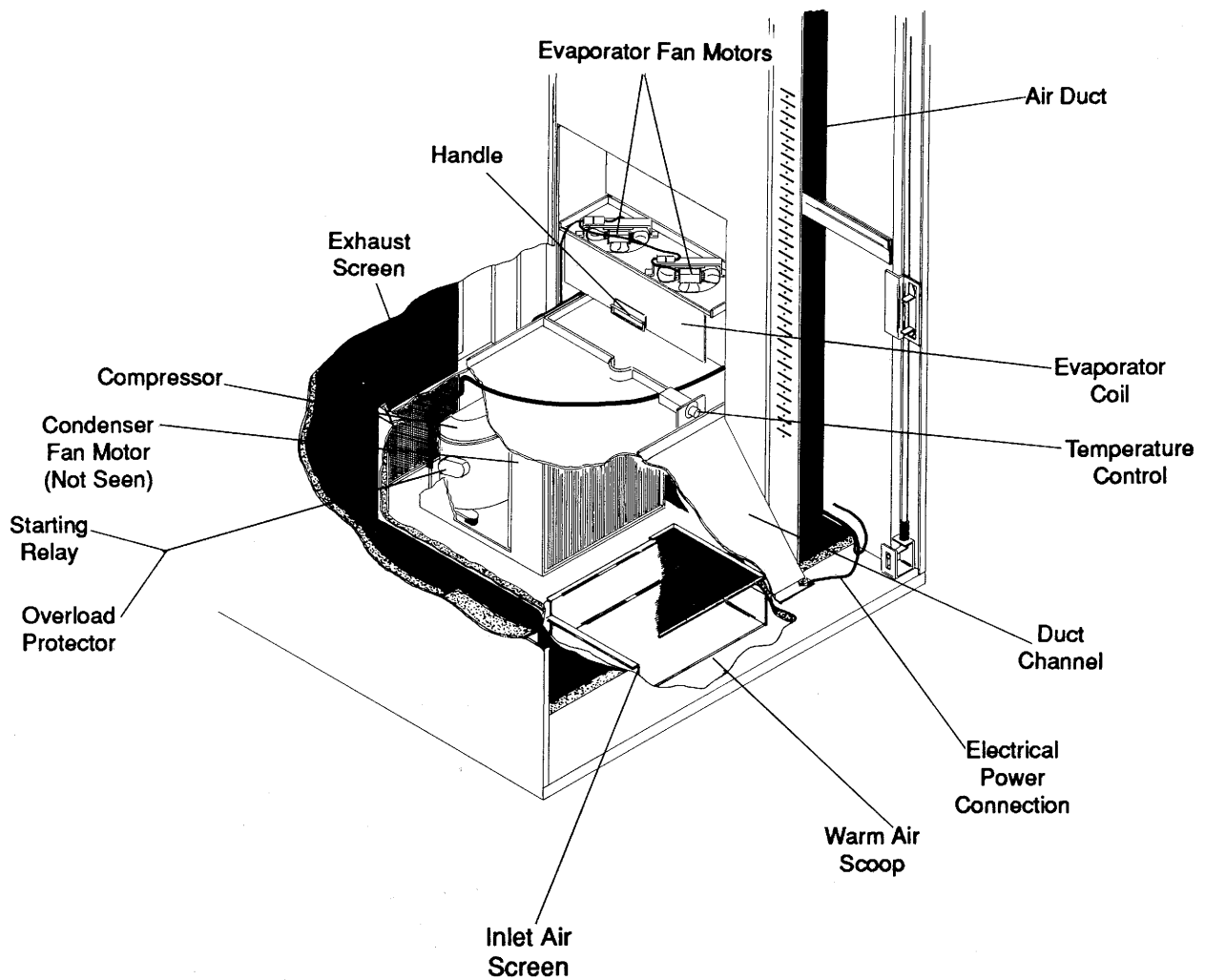
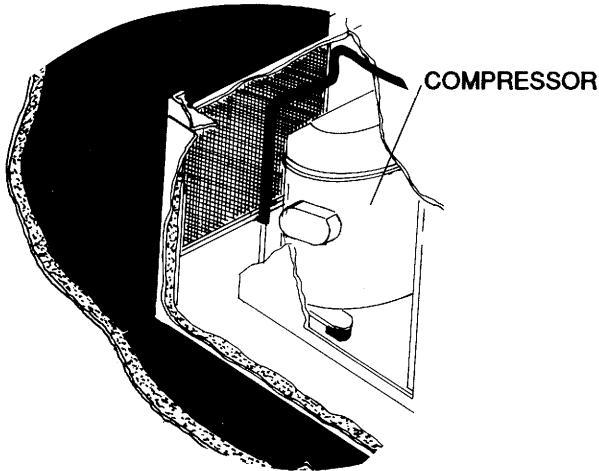

ILLUSTRATION #3

**Compressor (see Illustration #4):**

The compressor used is a 1/5 HP Tecumseh AE 3425 AA utilizing a Freon 12 charge of 10 fluid ounces to cool the system. This compressor operates on 115 VAC, 10 Amps circuit. The unit is turned on and off by the temperature control.



**ILLUSTRATION #4**

**Starting Relay:**

A current-dependent electromagnetic starting relay is used for cutting in and out the compressor motor start or main windings. When the relay coil and the main windings are subjected to the initial high start-up current, the relay contacts close. During the acceleration of the motor, the current through the main windings of the motor and the relay coil falls. When this current falls below a preset value the relay contacts open and the start windings drop out of the circuit. The run windings, which are always in the circuit, continue to run the compressor efficiently until the cold control is satisfied and shuts off. Care must be taken in the replacement of the relay which is precisely sized to each compressor model.

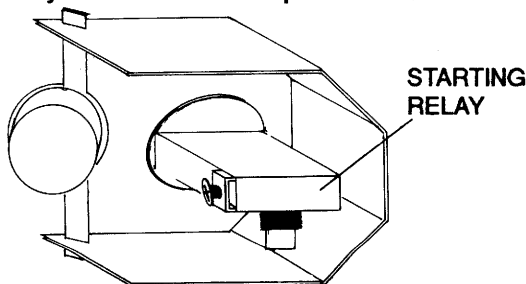

**ILLUSTRATION #5**

**Overload Protector (see Illustration #6):**

This bimetallic protector permits the compressor motor to perform beyond its normal duty up to a predetermined safe temperature limit without cutting off its power supply. The protector uses bimetallic discs to control a normally-closed switch. Heating of the bimetallic discs is a function of both temperature around the projector and the internal heat generated by the motor current through the discs. When the heat has reached the predetermined temperature the bimetallic discs' contact will open, causing the power to the compressor to stop.

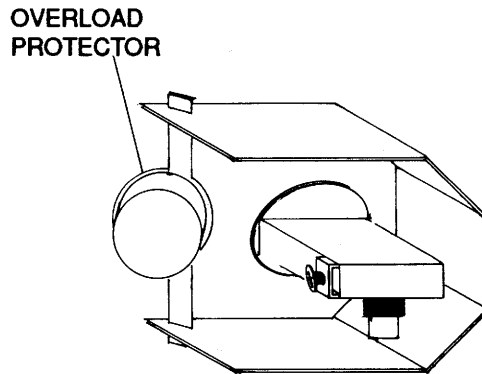

**ILLUSTRATION #6**

**Temperature Control (see Illustration #7):**

This device is the primary control which starts or stops the compressor unit. The control is adjustable and should be set at number "5" on the marked scale around the knob. As the temperature inside the insulated cabinet raises or drops, this control will either turn on or shut off the compressor and condenser fan motors.

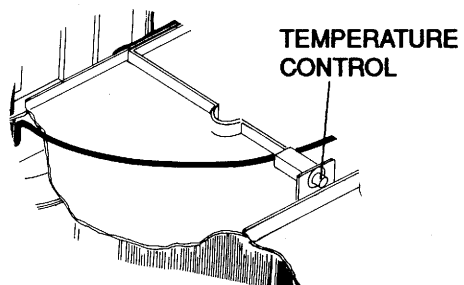

**ILLUSTRATION #7**

**Evaporator Fan Motors and Blades (see Illustration #7):**

This system uses two 25 watt, 115 VAC fan motors. These motors circulate the internal air around the insulated cabinet and through the evaporator coil remove heat from the cabinet. These motors will run continuously as long as the unit is connected to an electrical outlet.

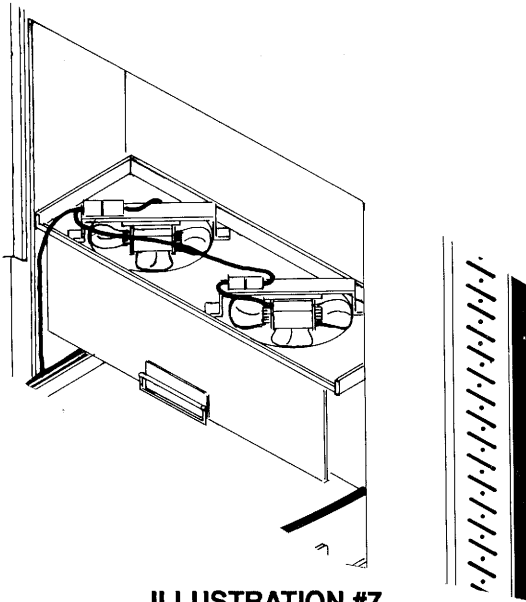

**ILLUSTRATION #7**

**Condenser Fan Motors (see Illustration #8):**

This system uses one (1) condenser fan motor, drawing air from the air intake scoop, connected to the bottom of machine, through the condenser coil. This fan motor is 6 watt, 115 VAC.

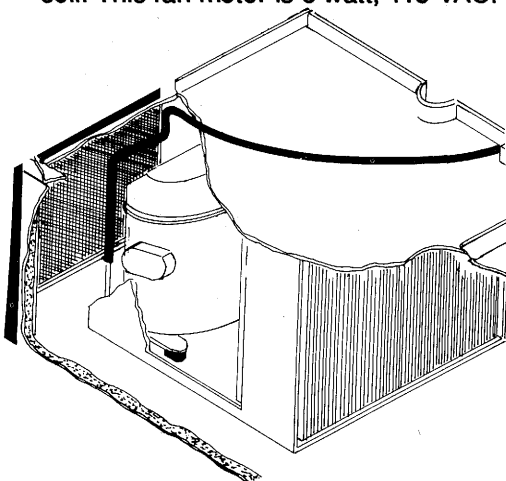

**ILLUSTRATION #8**

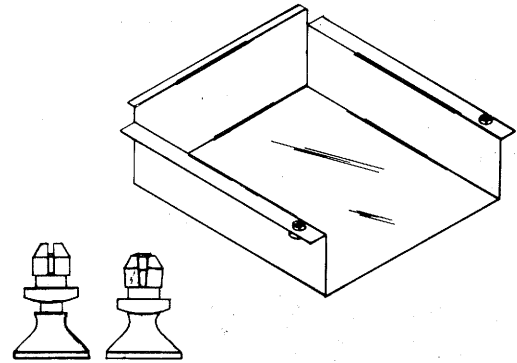

**ILLUSTRATION #9**

**Warm Air Scoop:**

The warm air scoop is shipped, packed inside the bottom of the cabinet next to the refrigeration system. The main purpose of this scoop is to draw air from the front of the machine to be used in the cooling of the refrigeration components.

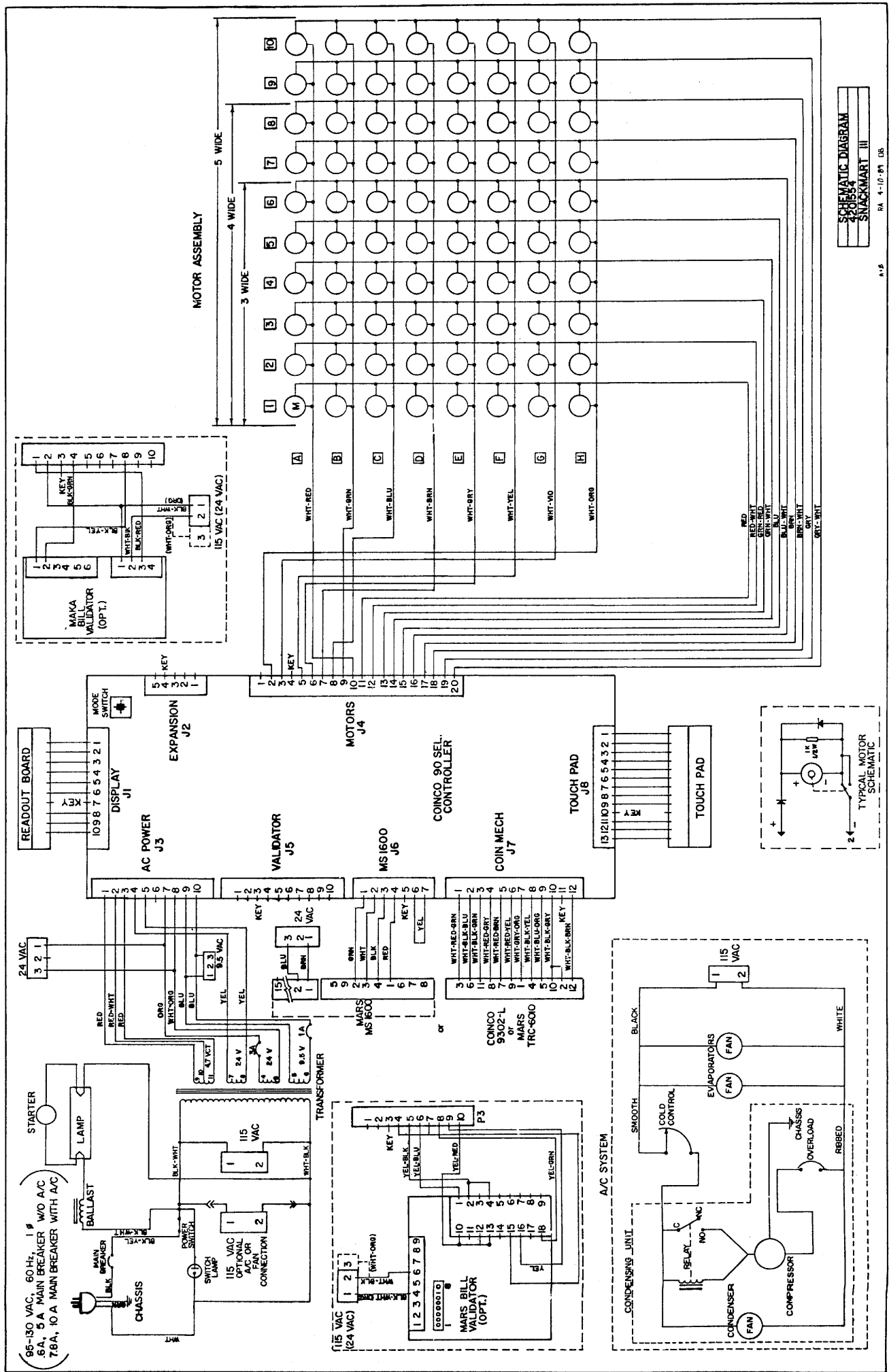

SCHEMATIC DIAGRAM  
 SNACKMART III  
 RA 4-10-81 DS

