

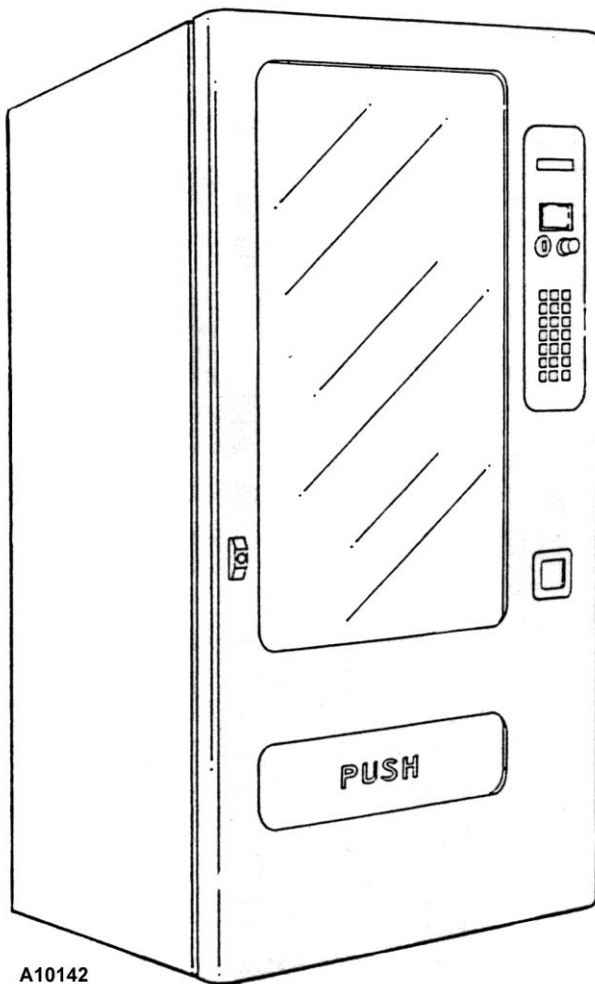

ROUND FRONT MERCHANDISER DX Series



A10142

MODELS:

3142

3143

3085MDB

3084MDB

SERVICE MANUAL

TABLE OF CONTENTS

<p>INTRODUCTION..... 1</p> <p>SPECIFICATIONS 2</p> <p style="padding-left: 20px;">GENERAL.....2</p> <p style="padding-left: 20px;">ELECTRICAL.....2</p> <p style="padding-left: 20px;">PRICING.....2</p> <p>UNPACKING..... 3</p> <p>INSTALLATION 3</p> <p style="padding-left: 20px;">POWER SWITCH.....4</p> <p>COINAGE OPERATION..... 4</p> <p style="padding-left: 20px;">FEATURES.....4</p> <p style="padding-left: 40px;">OPTION SWITCH SETTING.....4</p> <p>PRODUCT LOADING..... 5</p> <p>SETTING VEND PRICES 6</p> <p style="padding-left: 20px;">TO ENTER SERVICE MODE.....6</p> <p style="padding-left: 20px;">SETTING VEND PRICES.....7</p> <p style="padding-left: 20px;">VERIFYING VEND PRICES.....7</p> <p>INSTALLATION CHECKLIST 7</p> <p>CARE & CLEANING..... 7</p> <p style="padding-left: 20px;">CABINET EXTERIOR.....7</p> <p style="padding-left: 20px;">CABINET INTERIOR.....8</p> <p>CONTROLLER 8</p> <p style="padding-left: 20px;">VENDING SEQUENCE.....8</p> <p style="padding-left: 20px;">SERVICE MODE.....9</p> <p style="padding-left: 20px;">READING ERROR CODES.....9</p> <p style="padding-left: 20px;">PROGRAMMING INSTRUCTIONS.....9</p> <p style="padding-left: 40px;">COIN DISPENSE MODE.....10</p>	<p>MOTOR COUNT MODE 10</p> <p>CHECK MOTOR.....10</p> <p>RESETTING MOTORS (DOWNWARD CONFIGURATION).....10</p> <p>ACCOUNTABILITY10</p> <p>SETTING VEND PRICES.....11</p> <p>TEST VEND11</p> <p>POINT OF SALES MESSAGE12</p> <p>LANGUAGE SELECTION13</p> <p>VEND OPTIONS14</p> <p style="padding-left: 20px;">BILL ESCROW.....14</p> <p style="padding-left: 20px;">FORCE VEND.....14</p> <p style="padding-left: 20px;">MAXIMUM CHANGE.....14</p> <p style="padding-left: 20px;">SET TIME & DATE.....15</p> <p style="padding-left: 20px;">TIMED SHUT DOWN INTERVALS (School Timer) 15</p> <p style="padding-left: 20px;">ONE FREE PRODUCT.....17</p> <p style="padding-left: 20px;">PROMOTIONAL VEND.....17</p> <p style="padding-left: 20px;">CONTINUOUS TEST VEND OF MACHINE.....17</p> <p>BILL VALIDATOR17</p> <p style="padding-left: 20px;">REMOVING ACCEPTED BILLS.....18</p> <p style="padding-left: 20px;">TROUBLE-SHOOTING.....18</p> <p style="padding-left: 20px;">CLEARING JAMS & CLEANING.....19</p> <p>MACHINE ADJUSTMENTS19</p> <p style="padding-left: 20px;">CHANGING TRAY SPACING.....19</p> <p style="padding-left: 20px;">HELIX TIMING:.....20</p> <p style="padding-left: 40px;">SCROLL LOCKS (3 & 4-wide trays only).....21</p> <p style="padding-left: 40px;">PRICE LABELS (5-wide tray only).....21</p> <p style="padding-left: 20px;">QUICK REFERENCE SERVICE COMMANDS:.....22</p> <p>ELECTRICAL TROUBLESHOOTING23</p> <p>PRINTED CIRCUIT BOARD PIN-OUT27</p> <p>SCHEMATIC.....28</p>
---	--

Record the Model Number and Serial Number of your machine below.

The Model and Serial numbers are needed for you to obtain quick service and parts information for your machine. The numbers are given on the identification plate located on the back side of the cabinet of the machine.

MODEL NUMBER: _____

SERIAL NUMBER: _____

INTRODUCTION

The contents of this manual contains service and installation guidelines and instructions pertaining to the models 3142, 3143, 3084MDB and 3085MDB. Also included is the basic functions and operation of these vendors along with various options and accessories that are available for the machines. It is recommended that you read and thoroughly understand the information in this manual before attempting to put these vendors in operation.

The 24, 36 and 40 selection *Vendors* have been designed and engineered for many years of trouble-free merchandising, as well as maximum customer friendliness and simplified service and maintenance. Each vendor utilizes a “state-of-the-art” electronic control system which allows changing the programming and machine configuration on location without the need of any additional accessories or remote parts.

All selections can be priced individually at various vend prices ranging from \$.00 to \$99.95 in 5¢ increments.

Electrical malfunctions, service diagnostics, cash accountability and other information is recorded by the control system and will be available to service personnel when the machines are placed in the *Service Mode*.

Electrical functions are monitored during each vend and any malfunctions detected (faulty motors, switch operations, etc.) will be displayed to service personnel indicating the area where the problem was detected. When a malfunction is detected, that selection will be disabled, prohibiting any vends from being made until the controller has been reset. All other selections will continue to function.

During normal operation, messages will be displayed to the buying customer showing instructions that must be followed.

All models have the “mix-and-match” designed trays that will allow the changing of selection configurations by adding or reducing the number of motors and helixes. This allows a location to change the vendable products on the spot to meet the specific needs of the location.

Each vendor is capable of supporting a companion vendor for cold drinks which utilizes the existing controller, keypad, coin changer and bill validator.

Other features include:

- Larger display area for ultimate merchandising and product display.

- Unitized one-piece door, styled with an attractive European flair.
- Adjustable helixes for greater vend reliability.
- Drop-in 24 Volt DC, current limited motors for greater torque and “burn-out” protection.
- Vertical lighting for optimum product illumination.
- Electronic keypad to eliminate electro-mechanical push button switches.
- Programmable vend options to allow for the fine tuning of each vendor to meet the location’s needs.

In addition to a parts ordering catalog, optional kit information and wiring diagrams, this manual will detail in step-by-step form:

- * Unpacking and installing the vendor.
- * Loading product into the vendor.
- * Setting and displaying the vend prices.
- * Selecting the vend options.
- * Care and cleaning the vendor.
- * Testing the vendor.
- * Adjusting the vendor.
- * Bill Validator operation.
- * Trouble shooting the vendor.

It is recommended that this manual be read thoroughly to familiarize the service person with the functions of all components along with the features that are available. The initial set-up of a machine is a very important step of insuring that the equipment operates in a trouble-free manner. By following the instructions at the initial installation of the machine, service problems can be avoided and set-up time will be minimized.

All vendors have been thoroughly inspected prior to shipment and have been packed in a manner to prevent damage during transit.

Each machine will be identified by a model number and a specific serial number. These identification numbers appear on the serial number plate attached to the inside and rear of the vendors. An inspection number appears on the final inspection form in each vendor. Record these numbers for your records. Refer to these numbers when reporting any vendor imperfections.

SPECIFICATIONS

GENERAL

DIMENSIONS		MODELS					
		3085MDB		3084MDB 3142		3143	
		3-Wide		4-Wide		5-Wide	
		24 select*		36 select*		40 select*	
		US-inch	Metric-cm	US-inch	Metric-cm	US-inch	Metric-cm
Height	68 [◆]	173 [◆]	68 [◆]	173 [◆]	68 [◆]	173 [◆]	
Depth	34-1/8	87	34-1/8	87	34-1/8	87	
Width	29-1/4	74	35-3/16	89	41	104	
Weight	445 lbs.	202 kg	520 lbs.	236 kg	595 lbs.	270 kg	
Glass size	Width	17.687	45	23.531	59.8	29.375	74.6
	Height	41-15/16-in (106.5cm)					
	Thickness	1/8-in Tempered (3.175 mm)					
* Selection count will vary depending on vendor configuration.							
◆ 72-in. (183cm) with optional 4-in. (102cm) legs.							

ELECTRICAL

Power 115 VAC
 Cycle 60 Hz
 Current 1.2 Amp

PRICING

Capable of using a MDB Coin Mechanism, Bill Validator and Card Reader

UNPACKING

All vendors have been thoroughly inspected prior to shipment and have been packed in a manner to prevent damage during transit.

An inspection number appears on the final inspection form in each vendor and should be used when reporting any vendor imperfections.

Unpacking is accomplished in the following manner.

1. Cut and remove the banding straps that secure the shipping carton to the vendor.
2. Carefully lift the shipping carton up and away from the vendor. If ceiling height is not sufficient to allow this, carefully cut the carton taking care not to mar or damage the vendor's finish.
3. Remove the protective plastic bag.
4. Remove the base shipping boards by inserting a large screwdriver or prying tool into the notch provided and splitting the knock-away boards. See Figure 1.
5. Locate the key in the coin return cup and unlock the vendor. The "T" handle latch requires a minimum of three (3) full turns counterclockwise to open the main door.
6. Pull the power cord out of the vendor to its full length.
7. Carefully "seat" the rubber grommet on the power cord into the hole in the back of the vendor.
8. Remove all packing material, shipping brackets and tape from inside the vendor. Adhesive residue can be removed with denatured alcohol or common household vinegar.

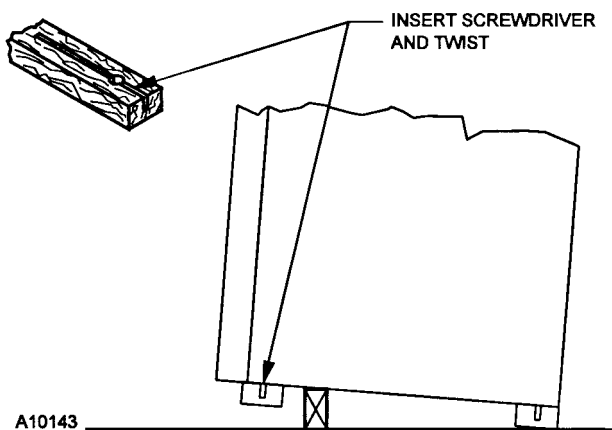

FIGURE 1. Removing Shipping Boards

INSTALLATION

Position the vendor in its place of operation no further than six (6) feet from a 115 Volt AC receptacle and check that the door will open fully without interference. For proper operation, especially in the coin changer, it is important that the vendor be perfectly level.

Level the vendor, making sure all levelers are touching the floor. When the vendor is level, the door can be opened to any position and not move by itself. Try the door half closed, straight out and in the wide open position before deciding the machine is level.

Connect the vendor power cord to a grounded 115 Volt AC, 60 Cycle, noise free polarized power source of not less than 15 Amps. Checking the power source can be accomplished with an AC Voltmeter in the following manner:

1. Voltage Check

When the AC Voltmeter probes are connected to the **HOT** and **NEUTRAL** terminals, the voltmeter should indicate 110 to 130 volts AC. See Figure 2.

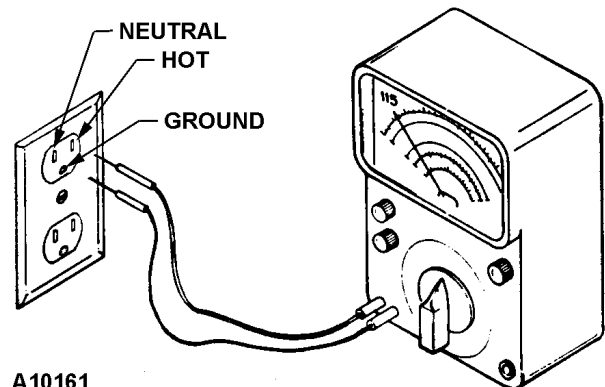

FIGURE 2. Electrical Check with Voltmeter

2. Polarity and Ground Check

When the AC Voltmeter probes are connected to the **HOT** and **GROUND** terminals, the voltmeter should indicate 110 to 130 Volts AC. See Figure 2.

3. Noise Potential Check

When the AC Voltmeter probes are connected to the **NEUTRAL** and **GROUND** terminals, the voltmeter should indicate 0 Volts AC. See Figure 2. Any voltage reading could cause noise problems in the electronic controller.

A. Amperage Check

At the fuse box or circuit breaker panel, locate the proper circuit and ensure that the fuse or breaker protecting that circuit is rated at 15 Amps or greater.

NOTE:

In a standard three (3) prong 115 Volt AC wall outlet the **GROUND** pin is round, the **NEUTRAL** pin is rectangular and located clock-wise from the ground pin and the **HOT** pin is rectangular and smaller than the neutral pin and located counterclockwise from the ground pin. See Figure 2.

To correct negative voltage, amperage, polarity, or ground checks, consult a licensed electrician. To correct a negative noise potential check, install a noise suppressor which can be obtained from any electrical or electronic supply store or in kit form from USI.

POWER SWITCH

Each vendor is equipped with a "Power Switch" located at the top center of side panel. See Figure 3. removing all power to the Controller, Selection Buttons, and complete vending circuit.

Turning the switch to the **on** position, see Figure 3, the product display light will come on, the validator motors will cycle and the display will scroll the **POINT OF SALES** message.

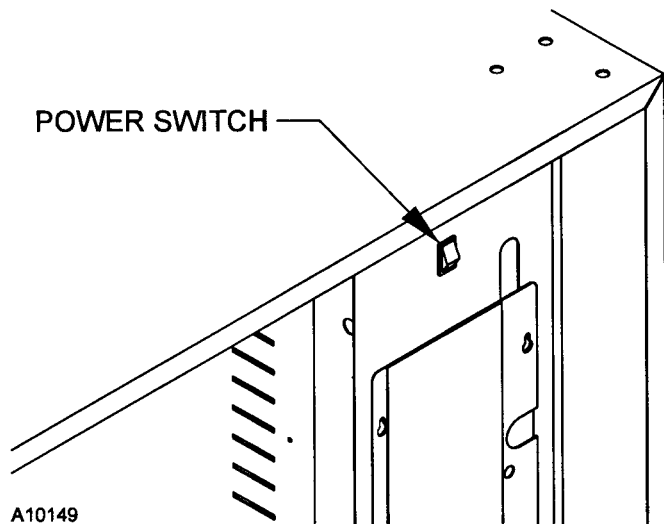

FIGURE 3. Power Switch

COINAGE OPERATION

Load the coin changer coin tubes with nickels, dimes and quarters. See Figure 4 If the "DEX/UCS" information is to be used see "Accountability - Fill Coins" section. The credit display will scroll the merchandising message

Table 1. Coin Tube Capacitys

	5¢	10¢	25¢ OPTION	
			HI 25¢	LOW 25¢
FULL LEVEL	68-69	98-99	66-67	8-9
LOW LEVEL	7-8	10-11	8-9	8-9

FEATURES

The coin mechanism pays out nickels, dimes and quarters from self-loading, high capacity change tubes in the least number of coins available.

CAUTION:

DO NOT PLUG OR UNPLUG COIN CHANGER WITH POWER ON!

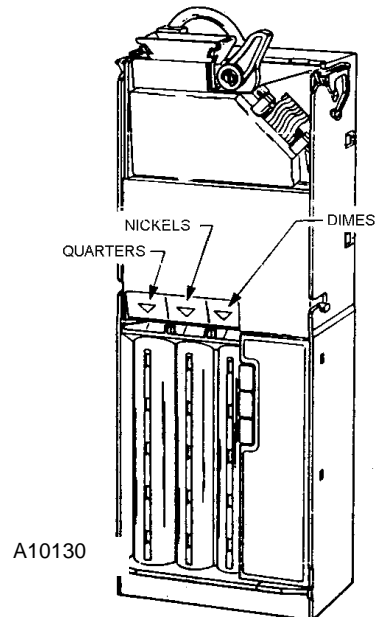

FIGURE 4. Coin Tubes

OPTION SWITCH SETTING

The coin changer has three (3) option switches which allow the owner/operator to select the type of coins to be accepted along with the number of quarters that will be stored in the 25¢ coin tube for overpayment. These switches have been factory set in the following positions:

- #1 - OFF
- #2 - OFF
- #3 - OFF

Should a different setting be desired, or a new changer installed, the following switch setting instructions are provided.

- A. Open the outer door to turn the main power switch to the **OFF** position. See Figure 3.
- B. Remove the coin acceptor portion of the coin changer. See Figure 5.

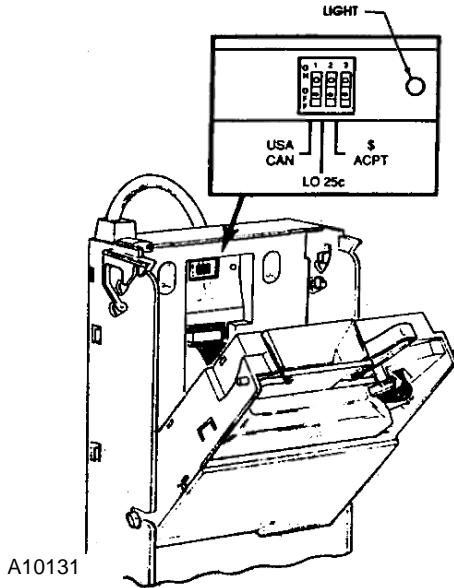

FIGURE 5. Option switches

- C. Locate the coin changer option switches and select from the following optional settings:

1. USA/CAN

- **ON:** U.S. and Canadian coins will be accepted.
- **OFF:** Canadian coins will be rejected.

2. LO 25¢

- **ON:** Quarters are diverted to cash box once the change tube has inventoried approximately 8 quarters.
- **OFF:** Quarters are diverted into the change tube until the change tube is full.

3. \$ ACPT

- **ON:** Dollar coins will be accepted.

- **OFF:** Dollar coins will be rejected.

NOTE

The bill validator operation of this vendor requires the "LO 25¢" option switch to be in the "Hi" or "OFF" position

The controller will monitor the condition of the coin changer at all times. Any activity (coins inserted) will be recorded in the accountability area and included in the "DEX/UCS" report. If the "DEX/UCS" information is to be used, the "FILL COINS" procedure should be used when manually filling the coin tubes. See "Accountability - Fill Coins" section of this manual for additional information.

PRODUCT LOADING

To load the trays with appropriate product, lift each tray slightly to disengage the detent and pull the tray forward until it stops. As the tray travels forward on its rail system, it will automatically tilt downward and allow easy access for servicing and loading. Load each shelf from front to back making sure all items fit freely between the helixes. Do not attempt to force oversize items into the spaces. All spaces forward **must** have a product in them; do not skip a space. General guidelines for each product type are as follows:

- A. **Large Snack Helix** - Large bagged items are generally loaded with the bottom of the product resting on the tray floor, spanning the helix coil.

NOTE

It is recommended that large popcorn items be vended in the top row, selections A-1 through A-7, and that a product spacer be used to vend these items with a chip product between popcorn bag selections or use the Dual Helix.

- B. **Medium Snack Helix (3 & 4-wide machines only)-** Medium bagged items and large candy/snack items are generally loaded with the bottom of the product resting on the tray bottom, between the helix coils.

- C. **Sandwich Cracker/Candy Helix** - Sandwich cracker and candy items are generally loaded with the bottom of the product resting on the tray bottom, between the helix coils.
- D. **Dual Helix** - Used for Popcorn items (light bags). Two helix coils turn in opposite directions from a single dual motor. Bagged items are generally loaded with the bottom of the product resting on the tray floor, centered between the helix coils.
- E. **Gum/Mint Split Helix - (Optional)** Gum, mint or extremely small snack items are generally loaded with the bottom of the product resting on the tray bottom, between the helix coils.

NOTE:

When loading the product, make sure that the product label is in full view to the buying customer. The product label should read from left to right or from bottom to top. See Figure 6.

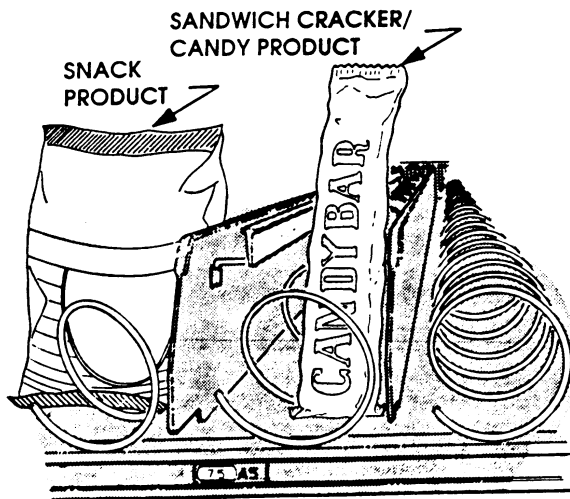

FIGURE 6. Loading example

SETTING VEND PRICES

All pricing is controlled by the controller and a price must be established for each selection. Selections can be individually priced in 5¢ increments from zero (free vend) to \$99.95. The vend prices for these vendors have been factory set. Should changes be necessary or should a new controller

be installed, the following price setting instructions should be followed:

Make sure that the Price Scroll (3 & 4-wide) or Price Label (5-wide) under the item agrees with the price programmed into the controller and the Price Scroll (3 & 4-wide) is secured in place with the scroll lock. See Figure 18.

TO ENTER SERVICE MODE

1. Open the outer door. Locate the white, main power switch plunger above the control board cover.
2. Pull the main power switch plunger out to the "ON" position.
3. Press the red Service Mode Button on the top right side of the control board cover. The control board is in the upper right side of the cabinet.
4. Error codes display if any errors have been detected by the controller. See Table 2 for explanations of codes.

To exit the *Service Mode* and return to the *Sales Mode*, press the Service Mode Button.

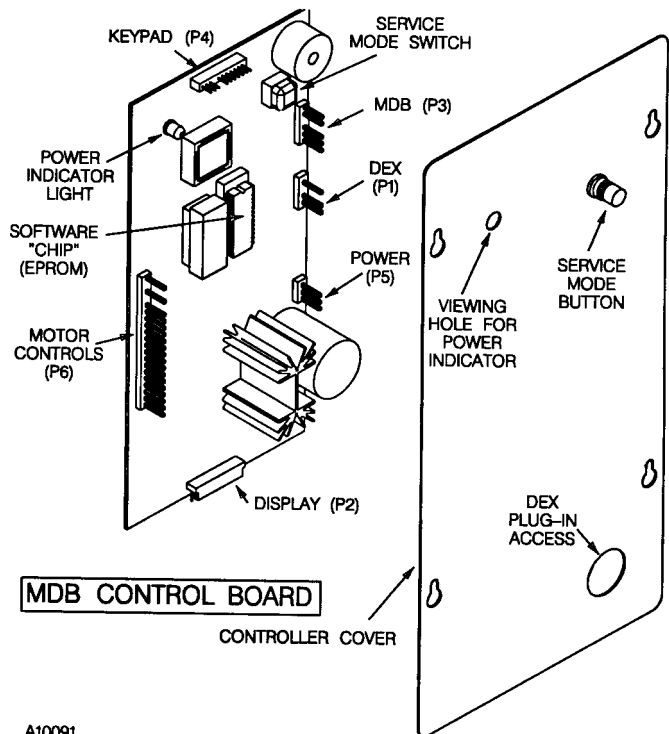

A10091

FIGURE 7. Control Board

SETTING VEND PRICES

1. Enter the *Service Mode*.
2. Press [5]. **SELECTION** displays.
3. Identify a selection. The selection and the current vend price displays.

To identify a selection, on the keypad press the letter and the number for that item.

EXAMPLE

To identify selection A4, press [A], then press [4].

4. Enter the new vend price using the number keys on the keypad. It is not necessary to enter leading zeros.

EXAMPLE

To set a vend price of \$.65, press [6], then [5].

- Valid prices are from zero (free vend) to \$99.95.
 - Prices can be set in 5¢ increments by individual selection, by row or by entire machine.
5. Then, choose between pricing one selection, one row, or the entire machine:
 - For a Single Selection press [10]
 - For an Entire Row press [11]
 - For an Entire Machine press [12]

NOTE

To cancel any unwanted settings press [13].

6. Exit the *Service Mode*.
7. Make sure the Price Scroll (3 & 4-wide) or Price Label (5-wide) under each selection on the tray agrees with the programmed price.

VERIFYING VEND PRICES

The vend price for each selection can be verified at any time while the machine is in the Sales Mode. To verify the price programmed into the controller, press the specific selection numbers. The selection number, followed by the current vend price will be displayed for approximately three (3) seconds. The price for each selection must also be identified by a Price Scroll (3 & 4-wide) or Price Label

(5-wide) located on the front of each tray, below each item.

Make sure that the Price Scroll (3 & 4-wide) or Price Label (5-wide) and the price programmed for each item agree.

INSTALLATION CHECKLIST

1. All shipping brackets, packing material and tape have been removed from the vendor.
2. Vendor is level and properly located for access to power source outlet.
3. Service cord plug-in-receptacle is properly grounded.
4. All components are installed on the vendor and are in good condition.
5. All vend prices have been set correctly.
6. All selections have been properly loaded and all items in each selection correspond to the vend price scrolls or price labels.
7. All options and features offered have been properly programmed into the controller. Refer to sections:

FORCE VEND OPTION
MAXIMUM CHANGE
PROMOTIONAL VEND OPTION
LANGUAGE SELECTION
TIME & DATE DISPLAY
TIMED SHUT DOWN

CARE & CLEANING

CAUTION:

Always disconnect power source before cleaning.

CABINET EXTERIOR

Wash with warm water and a mild detergent, rinse thoroughly and dry with a non-abrasive, lint free cloth. Wax occasionally with a quality grade liquid or paste auto wax. Minor scratches can be smoothed with rubbing compound, but deep scratches should be touched up with paint to prevent rust. Plastic parts should be cleaned with non-abrasive plastic cleaner. Jewelers "rouge" can sometimes be used to polish out scratches in plastic.

CABINET INTERIOR

Remove power from vendor. Wash with warm water and a mild detergent, rinse thoroughly and dry with a non-abrasive, lint free cloth. Offensive odors may be eliminated by adding baking soda or ammonia to the cleaning solution. Paint brushes may be used to clean hard to reach areas such as cabinet and delivery box corners. A damp sponge will pick up loose particles from the delivery box. The delivery box drain tube is equipped with a screen, which can be removed for cleaning.

The vend motors and helixes in the Vendor require no lubrication. Spray cleaners, lubricants or silicone may damage these moving parts. The nylon tray-rollers need no lubrication but do require occasional cleaning for smooth operation. The vend door and anti-cheat moving parts also require cleaning without lubrication. The main door hinges should require no lubrication, provided the cabinet is installed level. Occasional lubrication of the main door lock screw and lock nut with a quality lubricant, such as lithium grease, will allow the locking mechanism to function more smoothly.

The electronic coin changer is designed to operate without lubrication and minimal cleaning. Occasionally open the coin acceptor portion and wipe the exposed surfaces with a damp cloth.

For cleaning and caring for the bill validator see the Validator section of this manual.

CAUTION:

Electronic or electrical components should be kept free of water or other conductive liquids. Should any of these components be exposed to liquids, rinse and dry thoroughly with forced air, heat or time before restoring power to the vendor.

CONTROLLER

The MDB (Multi-Drop Buss) Controller will support a MDB coin mechanism, a MDB bill validator and up to a maximum of 70, 24 VDC motor driven selections. Also included is a DEX/USC interface that can be used to retrieve data using a DEX/UCS style Hand Held Computer (HHC).

Each time the controller is powered "on", it will default to the "sales mode" of operation, restoring the vend options to their state at power "off". The motor circuits will be checked and the controller will re-configure the vendor to its current state.

During the idle condition of the sales mode the controller will monitor the coin changer, bill validator and keypad for customer input. If no action is taken then the programmable "point of sales" message will be scrolled in the display. If the "Force Vend" option has been selected and the coin changer's coin tubes are below the "low" level sensors, the **PLEASE INSERT EXACT MONEY** message will be displayed.

The controller will allow acceptance of all coins as long as the accumulated credit is less than the maximum vend price of any selection. The amount of credit will be displayed as it is established. Coin acceptance will be disabled when credit has exceeded the highest vend price, during all vends, while coins are being paid out and while the controller is in the *Service Mode* of operation.

Bill acceptance will be allowed if the quarter tube of the coin mech is above the low level sensor or if the dime and nickel tubes are both above the low level sensors. If the accumulated credit is greater than or equal to the maximum vend price, then bill acceptance is disabled. If the bill validator is equipped with an escrow and the bill escrow feature is enabled and credit has exceeded the maximum vend price, the bill will be held in the escrow position. Otherwise the bill will go straight to the "bill stacker". If the bill validator does not offer escrow, or the bill escrow is disabled, the bill will go straight to the bill stacker.

VENDING SEQUENCE

The amount of credit established will be indicated in the display. When an alpha character is depressed on the keypad, a "beep" will be issued while the alpha is displayed. If a number is depressed within five (5) seconds, a "beep" will acknowledge the entry and one of the following series of events will occur:

1. If there has not been enough credit deposited, the selection's character, number and vend price will be displayed for approximately 1 second, with three "beep" tones, followed by a **PLEASE INSERT MORE MONEY** message being scrolled one time. The amount of credit, (or the point of sales message if no credit has been established), will be displayed again.
2. If there has been enough credit deposited, the selection's character, number and price will be displayed.
 - With **Force Vend OFF** - The controller will determine if the exact amount of change can be paid to the customer. If change can not be returned, the vend will be halted and the deposited credit will be returned in "like coin" fashion, three "beep" tones will be issued.

PLEASE INSERT EXACT MONEY message will be displayed and the idle condition of the sales mode will be resumed.

- With **Force Vend ON** - The selection will be vended. If for some reason the exact change cannot be returned, as much as possible will be paid out and the remaining amount will be retained as credit toward another vend. The amount retained will be displayed. If the correct change is returned, the **THANK YOU** message will be displayed for 0.8 seconds, followed by the idle condition of the sales mode.
3. If a motor is not allowed to complete a full cycle, or if after twelve seconds the motor has not yet returned to the home position, the controller will “beep” three times. The **MAKE ALTERNATE SELECTION** message is scrolled one time. This will be followed by the amount of credit.
 - With **Force Vend ON** the force vend feature will be overridden for approximately 25 seconds after a faulty vend. Credit will be returned if the coin return lever is pressed during that period.
 4. If a selection not in the configuration, or one with a bad motor is selected, the controller will “beep” three times and display the **MAKE ALTERNATE SELECTION** message. The credit or point of sales message will be displayed following this message.

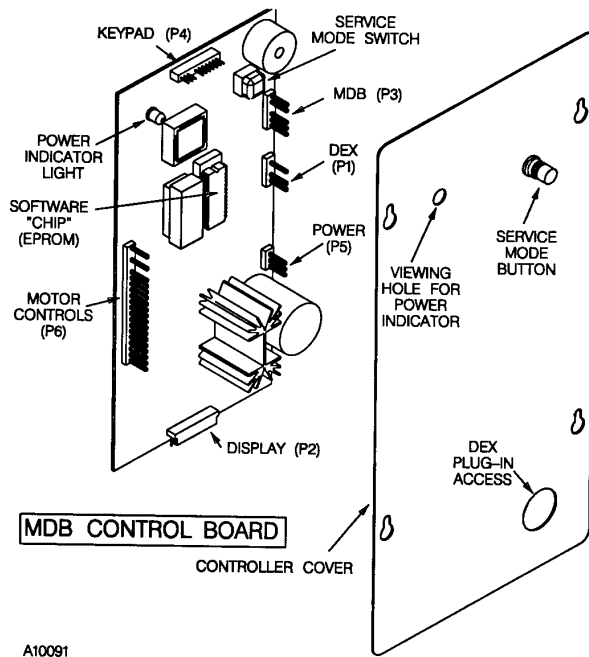

A10091

FIGURE 8. Control Board

SERVICE MODE

The *Service Mode* is entered by depressing the red Service Mode Button located on the top right side of the control board cover. See Figure 8. Upon entering the

service mode a “beep” will be issued to recognize the transaction. Diagnostics will be displayed if any errors have been flagged by the controller. If credit exists upon entry of the service mode, it will be restored when the sales mode is re-invoked.

The controller will automatically return to the sales mode within 25 seconds if no keypad entry is made during that time. Pressing the Service Mode Button again will also exit the Service Mode.

READING ERROR CODES

When entering the *Service Mode*, error codes (See Table 2) display on the front of the door if any errors have been flagged by the controller. Note any errors and correct.

Table 2. Service Mode Error Codes

CODE*	INDICATES	ACTION
xx 1*	Too little motor current (under 20 mA). Electrically open motor circuit.	Check motor xx*. Must perform a Test Vend to reset
xx 2*	Too much time to complete vend (12 seconds)	Check motor xx* and/or product jam. Must perform a Test Vend to reset
ERROR 3	Loss of coin mech. communications	Check coin mech. or harness connection for problem
ERROR 4	NOVRAM checksum error. Possible control board problem	Reset vend prices and Test Vend

* **xx** indicates the motor (selection) number

EXAMPLE

A7 1 indicates motor A7 is not operating.

PROGRAMMING INSTRUCTIONS

Table 3 lists the programming modes that can be accessed while in the *Service Mode*. The specific details and instructions of each mode are explained throughout this manual.

Table 3. Programming Modes

KEY INPUT	PROGRAMMING MODE
1	COIN DISPENSING
2	MOTOR COUNT
3	DOWNWARD CONFIGURATION
4	ACCOUNTABILITY
5	PRICE SETTING
6	TEST VEND SINGLE SELECTION
7	TEST VEND ENTIRE ROW
8	TEST VEND ENTIRE MACHINE
9	POINT OF SALES MESSAGE PROGRAMMING
10	LANGUAGE SELECTION
11	VEND OPTIONS
12	CONTINUOUS TEST VENDING OF MACHINE
13	TO EXIT SPECIFIC MODE OR EXIT SERVICE MODE

COIN DISPENSE MODE

To dispense a coin from the coin changer inventory tubes the controller must be placed in the *Service Mode*. While in the service mode, press the number [1] on the keypad. The controller will display **DISPENSE**. Pressing one of the following letters the coin changer will dispense the appropriate coins. The coins will continue to be paid out as long as the corresponding key is held depressed.

[A] = 25¢ Coin

[B] = 10¢ Coin

[C] = 5¢ Coin

[D] = \$1 Coin

To exit this mode and remain in the *Service Mode* press the number [13] on the keypad. To exit the *Service Mode* press the Service Mode Button.

MOTOR COUNT MODE

To access the Motor Count Mode the controller must be placed in the *Service Mode*. While in the service mode, press the number [2] on the keypad. When in the Motor Count Mode the controller will indicate the total number of functional motors that are in the system. The controller will check the electrical circuit of each motor to determine if it is complete at that instant. The message **MOTORS** followed by the number of functional motors will be displayed.

The motor count can be displayed again by depressing the number [2] on the keypad. Pressing and holding key [2], the count will be displayed constantly.

If the motor count displayed does not agree with the total number of selections in the machine, this indicates that the electrical circuit of all motors is not complete. The service person should determine what motor/motors are not functioning. Listed below are suggested steps to be taken.

1. Were faulty motors displayed when placed in the service mode?
 - Problem would be in these areas.
2. Test vend all selections.
 - Faulty motors will not vend.
3. Refer to the Trouble Shooting section of this manual for further assistance.

CHECK MOTOR

1. Visually inspect motor for broken connections or burnt wiring.
2. Switch non-functioning motor with a functioning motor: does the problem stay with the harness or move with the motor?
3. Reset motors (downward configure) if selections have been removed from configuration.

RESETTING MOTORS (DOWNWARD CONFIGURATION)

If a tray configuration is changed, use this mode to reset the controller to recognize all functional motors.

1. Enter the *Service Mode*.
2. Press [3]. The controller will reconfigure to the currently functioning motors and display **CONFIGURED**.
3. Exit the *Service Mode*.

NOTE

This is the only way to remove motors from the configuration.

ACCOUNTABILITY

Accounting data, such as total cash, total bills accepted and total vends is recorded for the total machine activity. This can be used to monitor the activity of the vendor.

To access the Accountability Mode the controller must be placed in the *Service Mode*. While in the service mode, press the number [4] on the keypad. The controller will display **ACCOUNTING** and wait for the following keypad inputs:

- A. Display value of all cash sales since initialization. This total is non-resettable and will rollover after \$99,999.95.
 - B. Display total value of bills accepted to the stacker since initialization. This total is non-resettable and will rollover after \$99,999.00.
 - C. Display total number of products vended since initialization. This total is not resettable and will rollover after 99,999.95.
 - D. Display total number of products vended since the last reset. This total will rollover at 79,999,920
 - E. Display **RESET** and wait for entry. At this point the totals that are maintained in [D] can be reset to zero. Press [F] to reset all resettable values.
 - G Display **FILL COINS** then show zero credit. As coins are entered the display will indicate the total value of the coins entered. This option is to be implemented for DEX operations. Pressing the number [13] on the keypad will exit this mode.
- 12 Display "DEX/UCS" and wait up to 25 seconds while allowing a DEX/UCS dump session to be initiated. Instructions and information contained in reports are outlined under **DEX/UCS SECTION**.

To exit this mode and remain in the *Service Mode* press the number [13] on the keypad. To exit the *Service Mode* press the Service Mode Button.

SETTING VEND PRICES

1. Enter the *Service Mode*.
2. Press [5]. **SELECTION** displays.
3. Identify a selection. The selection and the current vend price displays.

To identify a selection, on the keypad press the letter and the number for that item.

EXAMPLE

To identify selection A4, press [A], then press [4].

4. Enter the new vend price using the number keys on the keypad. It is not necessary to enter leading zeros.

EXAMPLE

To set a vend price of \$.65, press [6], then [5].

- Valid prices are from zero (free vend) to \$99.95.
 - Prices can be set in 5¢ increments by individual selection, by row or by entire machine.
5. Then, choose between pricing one selection, one row, or the entire machine:
 - For a Single Selection press [10]
 - For an Entire Row press [11]
 - For an Entire Machine press [12]

NOTE

To cancel any unwanted settings press [13].

6. Exit the *Service Mode*.
7. Make sure the Price Scroll under each selection on the tray agrees with the programmed price.

TEST VEND

Using the Test Vend modes does not affect the totals accumulated in the accountability records.

The controller will check the motor circuit and run the selection through a complete vend cycle if the circuit is complete and the motor is functional.

Place the controller in the *Service Mode*.

- ◆ Test Vend Single Selection: Press [6]. **SELECTION** displays.
 1. Identify the selection; the selection number and vend price display and the test starts.
 2. If the vend is successful, one "beep" will sound. If the vend is unsuccessful, three beeps sound.
 3. To test vend another selection, repeat Steps 2 and 3 outlined above.
- ◆ Test Vend Complete Row: Press [7]. **SELECTION** displays.
 1. Press the letter of the desired row. The selection number and the vend price of each selection display.
 2. If the test is successful one beep sounds and the test continues with the next motor. If the vend is not successful three beeps sound and the test continues with the next motor, until all motors in the row have been tested.

- ◆ Test Vend Complete Machine: Press [8]. **SELECTION** displays. The machine test starts with the last selection.
1. If the vend is successful the test continues with the next motor.
If the vend is not successful three beeps sound and the test continues with the next motor.
 2. When vends on all motors in the machine have been attempted, the test stops.
- Exit the *Service Mode*.

POINT OF SALES MESSAGE

Provisions have been incorporated into the controller for a “point of sales message” that will be displayed to the buying customer. This message can be used as advertising or encouragement to the buying customer to purchase the products. The point of sales message will appear continuously while the machine is in a standby condition as long as the Force Vend Option is off.

The sales message can be changed on location by accessing the point of sales message mode. Messages can include up to 105 characters including spaces. While in the programming mode the keypad buttons function similar to a typewriter keyboard. A key pad overlay indicates the positions of each letter or number. By placing the “overlay” over the selection panel a new message can be typed into the controller’s memory.

When entering the new message, **all inputs** will overwrite the previous message. If the maximum limit of 105 characters is entered, the message length is automatically saved.

To change the point of sales.
Place the controller in the *Service Mode* by pressing the Service Mode Button on the control board.

1. Press the number [9] on the keypad. See Figure 9.
 - The controller will display **MESSAGE**
2. Enter the new message.
 - Use the key pad overlay and refer to Figure 10 for location of characters on the keypad.
3. Save the message into the controller’s memory by depressing the [ENTER] key twice.

NOTE:

When in the Point of Sales Message Mode, the buttons on the keypad have different functions

A	0	1
---	---	---

B	2	3
C	4	5
D	6	7
E	8	9
F	10	11
G	12	13

FIGURE 9. Keypad in Standby Mode

A	G	M
S	Y	4
B	H	N
T	Z	5
C	I	O
U	0	6
D	J	P
V	1	7
E	K	Q
W	2	8
F	L	R
X	3	9
SPACE	SHIFT	BACK SPACE
*	ENTER	\$

FIGURE 10. Keypad in Standby Mode With Overlay

The upper characters in each block are accessed directly by depressing the desired key. The lower characters in each block identified as **Lower Case** in Figure 10 can only be accessed by depressing the **SHIFT** key **each** time those characters are needed.

To exit this mode, before starting a new message press the number [**13**] on the keypad. Once a new message is started the previously outlined steps must be followed to properly exit.

LANGUAGE SELECTION

During the normal operation of the vendor, default messages will be displayed, depending on the condition or function being performed. The controller can be programmed to display the default messages in different languages.

To select the message language, while in the *Service Mode* press the number [**10**] on the keypad. The controller will display **LANGUAGE** and wait for the appropriate letter. After the letter has been depressed, the nationality of the language selected will be displayed. Listed below are the various languages available:

A = Italian	E = English
B = Dutch	F = French / English
C = Spanish / English	G = German
D = Danish	11 = Auxiliary

If [**11**] is selected for the auxiliary language the controller will display **MESSAGE n** and wait for a message to be entered. This is done in the same fashion as explained under the "Point of Sales After starting a new message, the message must be saved before starting another "message" section. Pressing [**13**] while **MESSAGE n** is being displayed will save the previous message and advance through the message menu to exit the language mode.

All vendors, when shipped from the factory will be set to display the messages in the English language. All Auxiliary messages will be blank. The following messages will be affected by the language selection:

NOTE:

Selecting Auxiliary Language without programming will result in NO MESSAGES being displayed.

Message #1:

English: **PLEASE INSERT EXACT MONEY**
 Italian: **PER FAVORE INTRODURRE I PRECISI SOLDI**
 Dutch: **AFGEPAST GELD IN WERPEN**
 Spanish: **POR FAVOR DEPOSITE CANTIDAD EXACTA**
 Danish: **INDKAST AFTALTE PENGE**
 French: **FAITES L'APPOINT**
 German: **ABGEZAHLETS GELD EINWERFEN**
 Auxiliary: Programmable, maximum length 30

Message #2:

English: **PLEASE INSERT MORE MONEY**
 Italian: **PER FAVORE INTRODURRE PIU SOLDI**
 Dutch: **MEER GELD IN WERPEN**
 Spanish: **POR FAVOR DEPOSITE MAS DINERO**
 Danish: **INDKAST FLERE PENGE**
 French: **MONTANT INFUFFISANT INTROUISEZ D'AUTRES PIECES**
 German: **MEHR GELD EINWERFEN**
 Auxiliary: Programmable, maximum length 30

Message #3:

English: **MAKE ALTERNATE SELECTION**
 Italian: **FARE UNA ALTRE SCELTA**
 Dutch: **ANDERE KEUZE MAKEN**
 Spanish: **SELECCIONE OTRO PRODUCTO**
 Danish: **VAELG ANDEN VARE**
 French: **FAITES UNE AUTRE SELECTION**
 German: **ANDERE WARE WAHLEN**
 Auxiliary: Programmable, maximum length 25

Message #4:

English: **PLEASE CALL SERVICE**
 Italian: **PER FAVORE CHIAMARE SERVIZIO**
 Dutch: **SERVICEDIENST BELLEN**
 Spanish: **POR FAVOR LLAMAR MANTENIMIENTO**
 Danish: **TILKALD SERVICEMONTOR**
 French: **DEMANDEZ LE RESPONSABLE**
 German: **BITTE KUNDENDIENST RUFEN**
 Auxiliary: Programmable, maximum length 25

Message #5:

English: **VENDING OPERATION TO RESUME AT (hh:mm)**
 Italian: **VENDING OPERATION TO RESUME AT (hh:mm)**
 Dutch: **VENDING OPERATION TO RESUME AT (hh:mm)**
 Spanish: **VENDING OPERATION TO RESUME AT (hh:mm)**
 Danish: **VENDING OPERATION TO RESUME AT (hh:mm)**
 French: **VENDING OPERATION TO RESUME AT (hh:mm)**
 German: **VENDING OPERATION TO RESUME AT (hh:mm)**
 Auxiliary: Programmable, maximum length 25

Message #6: (Not applicable to these Vendors)

English: **MAKE SNACK SELECTION ONLY**
Italian: **DISPONIBILI SOLO LE SELEZIONI SNACK**
Dutch: **ALLEEN SNACK KEUZES**
Spanish: **SOLO DISPONIBLE PRODUCTOS EN
ESPIRAL**
Danish: **KUN VALG AF KONFEKTURE MULIGT**
French: **CHOISISSEZ UNIQUEMENT LES
CONFISERIES**
German: **NUR AUSGABE VON SUSSWAREN
MOGLICH**
Auxiliary: Programmable, maximum length 25

Message #7:

English: **THANK YOU**
Italian: **GRAZIE**
Dutch: **DANK U**
Spanish: **GRACIAS**
Danish: **TAK**
French: **MERCI**
German: **VIEL. DANK**
Auxiliary: Programmable, maximum length 10

Message #8

English: **FREE ON US**
Italian: **FREE ON US**
Dutch: **FREE ON US**
Spanish: **FREE ON US**
Danish: **FREE ON US**
French: **FREE ON US**
German: **FREE ON US**
Auxiliary: Programmable, maximum length 10

VEND OPTIONS

Vend options are available that can be programmed into the controller. These options allow the machine to be programmed to function as a changer without making a purchase, make multiple selections with single deposits, or vend a free item when selecting another, along with others as indicated in the following list:

- [A] = BILL ESCROW
- [B] = FORCE VEND
- [C] = MAXIMUM CHANGE
- [D] = SET TIME & DATE
- [E] = TIMED SHUT DOWN INTERVALS
- [F] = FREE PRODUCT MODE
- [G] = PROMOTIONAL VEND

To access the above modes the controller must be in the *Service Mode*. While in the service mode, press the number [11] on the keypad. The controller will display **OPTIONS** and wait for the appropriate letter as defined above.

BILL ESCROW

The purpose of this feature is to prevent the vendor from being used as a “changer”. When in the **ON** position, this option will allow the last bill accepted to be returned, provided the bill validator is equipped with an “escrow” feature. If the validator has the escrow feature, the bill will

be returned when the “coin return” command is initiated (coin return button is pushed). When in the **OFF** position, all bills inserted are routed directly to the stacker and when the “coin return” command is initiated, change will be returned to the buying customer.

To set the Bill Escrow options the controller must be in the *Service Mode*. While in the service mode press the number [11] on the keypad. The controller will display **OPTIONS** and wait for the appropriate letter as defined above. Press the letter [A] after the [11]. The current (**on** or **off**) state will be displayed as **ESCROW xxx** Pressing [A] again will toggle the on/off state.

To exit this mode and remain in the Service Mode press the number [13] on the keypad. To exit the Service Mode press the Service Mode Button.

FORCE VEND

When in the **ON** position, this option will force the buying customer to complete a purchase once they have deposited money of any form. The coin return command is disabled. If a vend is attempted and the motor fails during this vend, the customer will be allowed to escrow the credit for up to 25 seconds, regardless of the force vend setting. When in the **OFF** position the controller will allow the buying customer to cancel the transaction at any time and have the credit returned when the coin return command is initiated. A purchase of a product does not have to be made.

To set the Force Vend options the controller must be in the *Service Mode*. While in the *Service Mode* press the number [11] on the keypad. The controller will display **OPTIONS** and wait for the next input. Press the letter [B]. The current (**on** or **off**) state will be displayed as **F VND xxx**. Pressing [B] again will toggle the on/off state.

To exit this mode and remain in the Service Mode press the number [13] on the keypad. To exit the Service Mode press the Service Mode Button.

MAXIMUM CHANGE

The Maximum Change Mode is used to control the maximum amount of change that will be refunded on over deposit. This option will prevent change from being returned to the customer until the credit amount is less than or equal to the programmed maximum change limit. This mode is only recommended when there is a wide spread between the lowest vend price and the highest vend price of items. When the maximum change mode is initiated the credit amount **must** be equal to or less than the programmed amount before change will be refunded.

To set the Max Change options the controller must be in the *Service Mode*. While in the *Service Mode* press the

number [**11**] on the keypad. The controller will display **OPTIONS** and wait for the next input. Press the letter [**C**]. The current (**on** or **off**) state will be displayed as **MAX CHG xxx**. Pressing [**B**] again will toggle the on/off state. Press [**10**] to save.

If the ON mode is selected a second menu will appear and the controller will display **MX CHG xxx**. This can be modified in the same manner as described in the price setting procedure. Press [**10**] to save settings. To cancel an unwanted setting before saving, press [**13**].

To exit this mode and remain in the Service Mode press the number [**13**] on the keypad. To exit the Service Mode press the Service Mode Button.

NOTE

The time and date must be set if either DEX/UCS or the Timed Shut Down Intervals option is to be used.

SET TIME & DATE

1. On the controller cover inside the cabinet, press the Service Mode Button to enter the *Service Mode*.
2. Press number [**11**] on the keypad. **OPTIONS** displays.

NOTE

The controller operates on a 24-hour format. Time displays as **TIME hh.mm** (i.e. 17.14 is 5:14 PM).

3. Press the letter [**D**]. The current time displays.
4. To change the time, press the numeric keys. Press key [**10**] to save.
5. The current month displays as **MONTH mm**, where **01** = January, **02** = February ... **12** = December.
6. To change the current month, press the numeric keys. Press [**10**] to save.
7. The current date (**1 - 31**) displays as **DATE dd**.
8. To change the date, press the numeric keys. Press [**10**] to save.
9. The current day of the week displays as **DAY d** where **d** indicates **1** = Sunday, **2** = Monday, **3** = Tuesday, **4** = Wednesday, **5** = Thursday, **6** = Friday, **7** = Saturday.
10. Use the numeric keys to change the day. Press [**10**] to save.
11. The current year displays as **YEAR yy**. (i.e. **98** = 1998)

12. To change the year, press the numeric keys for the last two digits of the year. Press [**10**] to save.

To cancel an unwanted setting without saving, press [**13**] or exit the *Service Mode* by pressing the Service Mode Button.

TIMED SHUT DOWN INTERVALS (School Timer)

This option shuts down the machine during specified intervals of the day. All vending functions of the machine will be disabled. Four programmable intervals are available. If set to **ON**, during these time intervals the message **VENDING OPERATION TO RESUME AT hh.mm** displays. (i.e. **9.05** = 9:05 am, **15.34** = 3:34 p.m.) The current time and date must be set before specifying the intervals.

1. Press the Service Mode Button located on the controller cover inside the cabinet to enter the *Service Mode*.
2. Press the number [**11**] on the keypad. **OPTIONS** displays.
3. Press the letter [**E**]. **TIMES ON** or **TIMES OFF** displays, indicating the current setting.
4. Press [**E**] to toggle the ON/OFF setting.

NOTE

If the ON state is selected, four intervals with a start and a stop time for each, must be programmed. If an interval is not used, program the start and stop times to zeros (00.00).

The controller operates on a 24-hour format. Time displays as **TIME hh.mm** (i.e. **17.14** is 5:14 PM).

5. If the ON state is selected, wait approximately one second, **1STRT hh.mm** will display (i.e. **1STRT 13.12** = shutdown at 1:12 p.m.), indicating the starting time for the first shutdown interval.

6. To change this start time, use the numeric keys on the keypad. Press the number [10] to save.
7. **1STOP hh.mm** displays, indicating the ending time for the first shutdown interval. To change the ending time for the first shutdown, press the numeric keys. Press the number [10] to save.

NOTE

This is the time the machine will start up again after being shut down during the first interval.

8. **1DYXXXXXX** displays, indicating which days of the week this interval applies to. **0** = OFF and **1** = ON. The first **X** indicates the status for Sunday, the second for Monday, and so on, until Saturday. (i.e. **1DY0 1 1 1 1 1 0** = the first interval is used on all days except Saturday and Sunday).
9. To change the daily status:
 - press [1] to activate that time interval for shutting down the machine or
 - press [0] to not use that interval on that day.

10. When the desired setting is displayed for all seven days, press [10] to save. This completes the settings for the first interval.
11. **2STRT hh.mm** displays, indicating the starting time for the second shutdown interval.

Repeat steps 5 through 12 until all four intervals have been set. When finished with the fourth interval, the controller will return to the *Service Mode*.

To cancel an unwanted setting before saving, press [13] or exit the *Service Mode* by pressing the Service Mode Button.

NOTE

All four time intervals must be set. Each start and stop time must be set for proper operation. If an interval is not needed, set the start and stop times to zero (00.00).

EXAMPLE

TO	PRESS	DISPLAYS
Enter Service Mode	Service Mode Button	
Access Options Mode	[11]	OPTIONS
Set School Timer Option ON	[E]	TIMES ON
Set Interval 1 Start time to 8:00 am	[8][0][0]	1STRT 8.00
Set Interval 1 End time to 11:30 pm	[1][1][3][0]	1STOP 11.30
Use Interval 1 on Monday, Tuesday, Wednesday, Thursday and Friday	[0][1][1][1][1][1][0]	1DY0 1 1 1 1 1 0
Set Interval 2 Start Time to 1:00 pm	[1][3][0][0]	2STRT 13.00
Set Interval 2 End Time to 4:00 pm	[1][6][0][0]	2STOP 16.00
Use Interval 2 on Monday, Tuesday, Wednesday, Thursday and Friday	[0][1][1][1][1][1][0]	2DY0 1 1 1 1 1 0
Set Interval 3 and 4 to zero	[0][0][0][0]	3STRT 00.00
Set Interval 3 End Time to 00:00	[0][0][0][0]	3STOP 00.00
Set Interval 4 Start Time to 00:00	[0][0][0][0]	4STRT 00.00
Set Interval 4 End Time to 00:00	[0][0][0][0]	4STOP 00.00

What has been set?:

On Monday, Tuesday, Wednesday, Thursday and Friday the machine will not vend from 8:00 a.m. until 11:30 a.m. and from 1:00 p.m. until 4:00 p.m.

ONE FREE PRODUCT

This option will allow a free product to be given to the customer at a programmed interval. When enabled the product will be vended at no cost, all accumulated credit will be returned, and a message **FREE ON US** will be displayed during the vend process. Setting this interval to '1' provides a free vend at every transaction, '0' disables the option, and the maximum valid interval is 255.

To access this option the controller must be in the *Service Mode*. While in the service mode press the number [11] on the keypad. The controller will display **OPTIONS**. Press the letter [F] The controller will display **FREE xxx**, indicating the current interval that a free product will be dispensed.

EXAMPLE:

If **FREE 75** was displayed, the free product would occur every 75th vend.

A new interval may be entered by pressing the numeric keys, these will be displayed as they are entered. When the desired interval is displayed, press the number [10] to save.

To cancel an unwanted setting before saving, press [13] or exit the service mode.

PROMOTIONAL VEND

This option allows the customer to receive an additional product "free" when purchasing another. A maximum of two (2) promotional items can be programmed into each machine. The promotional or free item will always be dispensed from the #2 selection of a row. The primary product will be dispensed from the #1 selection of a row. When enabled, purchasing selection '1' from one of the two possible promotional rows will result in both selection '1' and '2' of that row to vend sequentially. Individual vends from selection "2" can be obtained while in promo vend if these selections are depressed with adequate credit inserted.

To access this option the controller must be in the *Service Mode*. While in the service mode press the number [11] on the keypad. The controller will display **OPTIONS**. Press the letter [G] The controller will display **PROMO xxx** indicating the current on/off state. Pressing [G] again will toggle the on/off state.

To program the promotional rows after selecting the ON option, wait 1 second and the display will continue to **ROWS X X**. The X's will indicate the current promotional rows programmed. (Row A, Row B, etc.). If the promotional rows were never selected the display will show - New rows may be entered by pressing the alphabetic keys. To clear any previous entries, press the

number key [12] and enter the new row/rows. When the desired selection is displayed, press the number [10] to save.

To cancel an unwanted setting before saving, press [13] or exit the *Service Mode* by pressing the Service Mode Button.

CONTINUOUS TEST VEND OF MACHINE

This option will allow a continuous test vend of all motors in the present configuration of the entire machine. The test will start with the last motor and run each motor in the configuration in reverse sequence. As each corresponding vend is attempted, the controller will display the selection number and vend price of that selection. If the vend is successful, the controller will pause for approximately 400 mS, then continue to the next motor. If the vend is not successful, the controller will stop the test vend operation and flash the selection number of the failed motor. If all motors in the configuration are successfully vended, the controller will pause for 15 seconds and then the cycle will be restarted.

To start the test procedure the controller must be in the *Service Mode*. While in the *Service Mode* press the number [11] on the keypad. The controller will display **OPTIONS**. Press the number [12] on the keypad three (3) consecutive times in rapid succession.

To stop the test vend cycle or to exit this mode, press the number [13] and hold until the current motor has been successfully vended. To exit this mode press the Service Mode Button.

BILL VALIDATOR

The BA32SA bill validator contains an option switch module allowing the unit to be customized to the requirements of an individual account. The following chart shows the functions of the option switches:

SWITCH	ON	OFF
1	High Security	Standard Acceptance
2	Accepts bills in one direction only (face up, green seal first)	Accepts bills in both directions (face up)
3	Serial or Parallel Interface	Pulse interface
4	\$20 Accept	\$20 Reject
5	\$10 Accept	\$10 Reject
6	\$5 Accept	\$5 Reject
7	\$2 Accept	\$2 Reject
8	\$1 Accept	\$1 Reject

All validators shipped from the factory will be set with switches #3 & #8 in the **ON** position. All other switches will be set to the **OFF** position. If you desire settings

different from those set at the factory, follow the steps outlined below:

1. Remove power from the validator by turning the main power switch to the **OFF** position. See Figure 3
2. Remove the retaining screw that secures the logic board and strain relief. see Figure 11.
3. Slide the logic board downward to expose the option switch module.
4. Set the option switches to the desired setting.
5. Reassemble the bill validator in reverse order of disassembly.
6. Reapply power, the stacker motor should cycle.
7. Test for proper operation.

fully latched in place when it is returned to the validator.

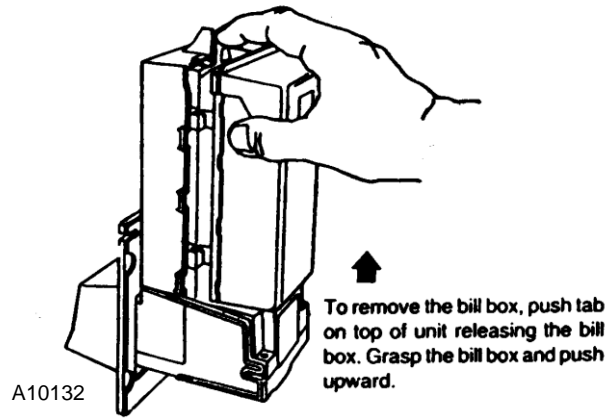

FIGURE 11. Removing Bill Box

TROUBLE-SHOOTING

Trouble-shooting can be achieved by reading flashes or blinks of light from the (red) LED located on the side of the logic board cover. These flashes can be seen through the grey smoked cover. See Figure 12 and Table 4. During normal operation the LED will be a steady or constant red.

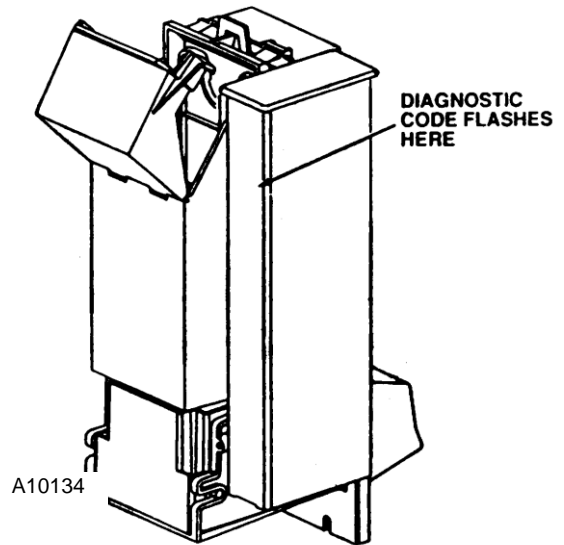

FIGURE 12. Diagnostic Code Flashes

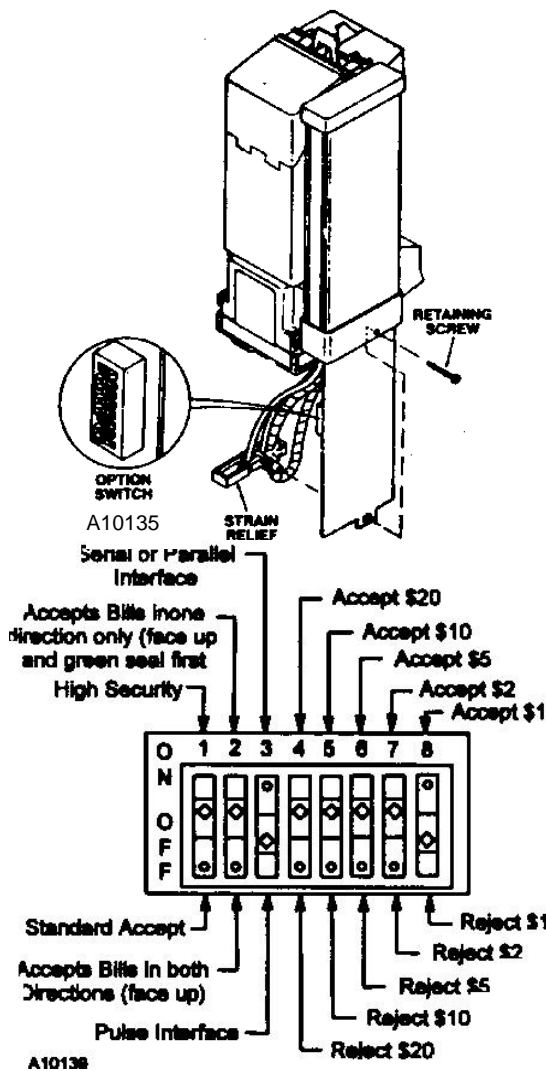

FIGURE 10. Validator Option Switches

REMOVING ACCEPTED BILLS

Accepted bills may be removed by opening the "bill box" lid or by removing the bill box from the validator. See Figure 11. If the bill box is removed, **make sure that it is**

Table 4. Diagnostic Codes

NO. OF FLASHES	DESCRIPTION OF DIAGNOSTIC CODES
No Flashes	Check Power and Harnessing to Validator
1	Bill Box Full
2	Bill Box Lid is open or not latched in place.
3	Check Bill Path
4	All Bill Accept Switches are Off
5	Bill Jam or Sensor Error
6 or more	Reset (Remove and Apply Power) or service required.

CLEARING JAMS & CLEANING

Trapped bills, debris or dirt can result in poor bill acceptance or bill rejection. Remove the "bill box" and lower housing to clear trapped bills or debris. See Figure 13. Clean the bill path plastic parts or belts with a cloth moistened with a mild soap and water solution. Clean the magnetic head and optic sensors using a swab and isopropyl alcohol. **Do not use any petroleum based cleaning solvents, scouring pads or stiff brushes for cleaning.**

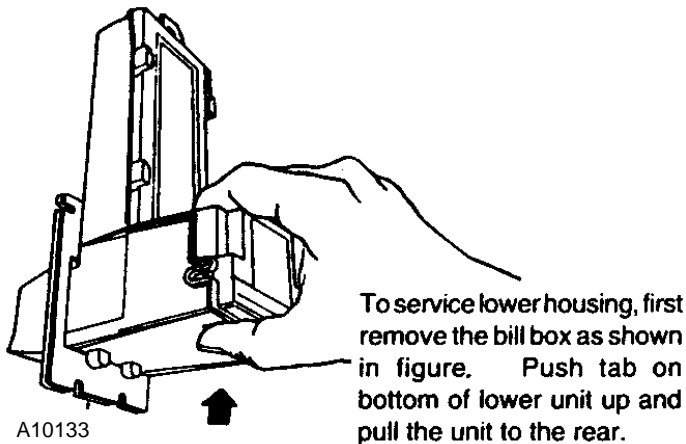

FIGURE 13. Remove Lower Housing

MACHINE ADJUSTMENTS

Adjustments to tray spacing, tray configuration and helix timing are provided to enhance the merchandising features of the vendor. By altering the tray spacing, larger items can be vended. By changing the tray configuration, different product mixes can be accommodated. By re-timing the helixes, difficult to vend items can be delivered more dependably.

CHANGING TRAY SPACING

The trays can be raised or lowered in one inch increments within a four inch range to provide additional headroom for vending larger items.

NOTE:

When increasing the headroom between two trays, a corresponding decrease in headroom of an adjoining tray will result.

To change tray spacing, follow the steps outlined below:

1. Pull out the tray to be adjusted until it stops.
2. Disengage the tray harness from its snap open harness clamp on the right hand side wall. See Figure 14.

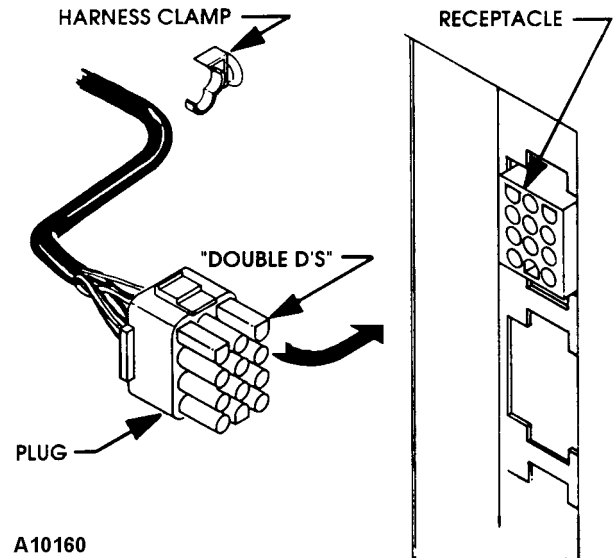

FIGURE 14. Tray Harness

3. Disconnect the tray plug from its receptacle on the right hand side wall. See Figure 14.
4. Lift up on the front of the tray and pull slightly (approximately 1/2") forward to clear the tray stop.
5. Lift up on the rear of the tray and remove it from the vendor.
6. Disengage both left and right tray rails from their corresponding slots on the left and right side walls by pulling inward on the bottom front of each rail and lifting its flange out of the slot. See Figure 15.
7. Pull each rail forward to disengage its rear tabs from the hole in the rear wall. See Figure 15.

8. Re-locate both left and right rails by reversing steps 5 and 6.
9. The rails must be level from front to back and evenly spaced from top to bottom on each side.
10. Replace the tray by placing its rear rollers on the left and right rails and lifting up on the front of the tray as it is pushed back.
11. Re-connect the tray plug to its receptacle.
12. For proper plug to receptacle orientation the two flat sided connectors (**Double D's**) on the plug should be up. See Figure 14.
13. Secure the tray harness with the harness clamp and snap it closed.
14. Test vend the tray in its new position to assure that the tray plug is properly connected.

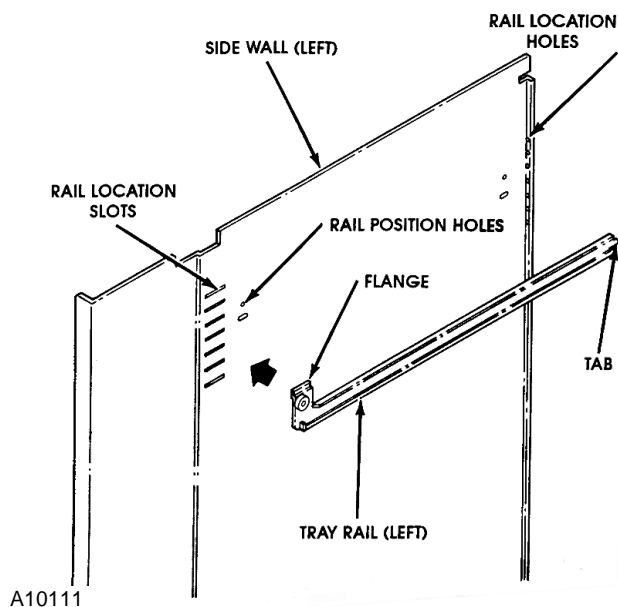

FIGURE 15. Tray Rail

HELIX TIMING:

The helix is connected to the motor via an 18 tooth helix hub spline into an 18 tooth internal gear in the motor gear case. This relationship provides a helix timing adjustment in 20 degree increments to alter the product drop-off point at the front of the tray.

Research and testing have determined that a vast majority of all products tested will vend successfully with the leading edge of the helix set at approximately 6:00 o'clock.

This adjustment has been selected as the "Middle of the Road" setting from which adjustments can be made in either direction.

Should you experience difficulty in vending odd size or shaped items, the helix can be re-timed by following the steps outlined below. The positioning of the helix will be on a trial and error basis.

1. Pull the tray containing the helix to be re-timed forward to its stop.
2. Remove all product from the compartment.
3. **3 & 4-wide** - Depress the motor cover latch and remove the motor cover. See Figure 16. **5-wide** - Remove the three thumbscrews securing the motor cover. Remove the cover.

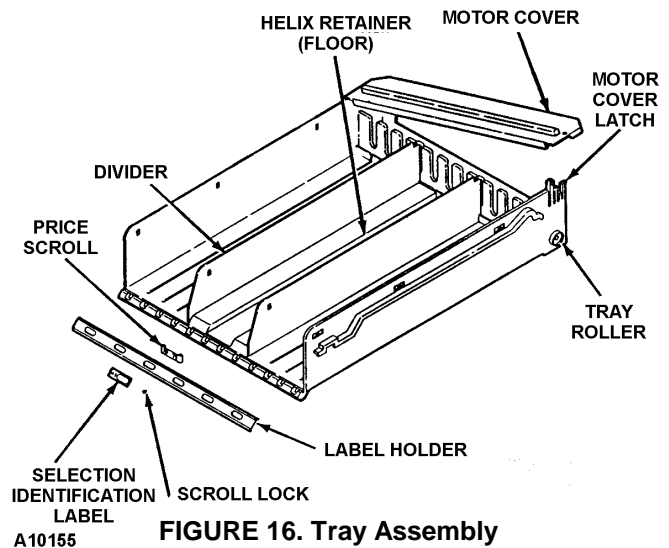

FIGURE 16. Tray Assembly

4. Lift the helix and motor slightly (approximately $\frac{3}{4}$ -in to disengage the helix hub from its retaining rib in the bottom of the tray. See Figure 17.
5. Separate the helix and hub from the motor slightly (approximately 1-in) by pulling forward on the helix hub to disengage its spline from the motor's internal gear. See Figure 17.
6. Rotate the helix and hub in either direction and re-install by pushing the spline into the internal gear of the motor.
7. Push down on the motor and helix hub to re-seat the helix hub onto its retaining rib in the bottom of the tray. See Figure 17.

8. **3 & 4-wide trays-** Replace the motor cover by hooking the left end into its retainer on the tray and snapping the right end into the motor cover latch. See Figure 16.
- 5-wide tray-** Replace the motor cover and secure with the three thumb screws.
9. Load the helix with the appropriate product for testing.
10. Push the tray back to its normal position making sure it is properly seated.
11. Test vend product and re-adjust if necessary.

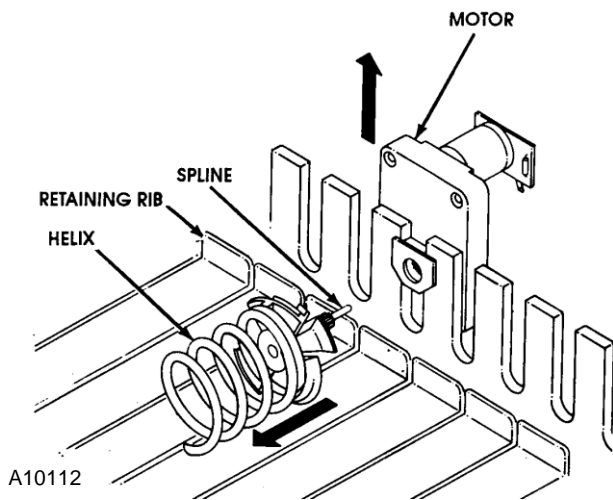

FIGURE 17. Helix Coupling

SCROLL LOCKS (3 & 4-wide trays only)

Rubber scroll locks are included in the service packet and are used to lock the price scrolls in place so they will not move due to tray vibrations etc. Set the price to where needed and insert the scroll lock into the small hole beside the scroll port. See Figure 18.

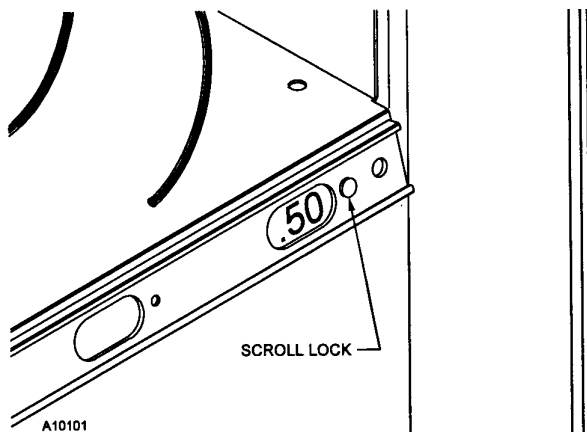

Figure 18. Scroll Locks

PRICE LABELS (5-wide tray only)

The 5-wide tray utilizes price labels for each selection. The tray label has selections A1 thru A0 etc. showing on the front rail. When a snack selection is configured in a tray, slide the price label over to cover the selection label (usually an even numbered selection). See Figure 19.

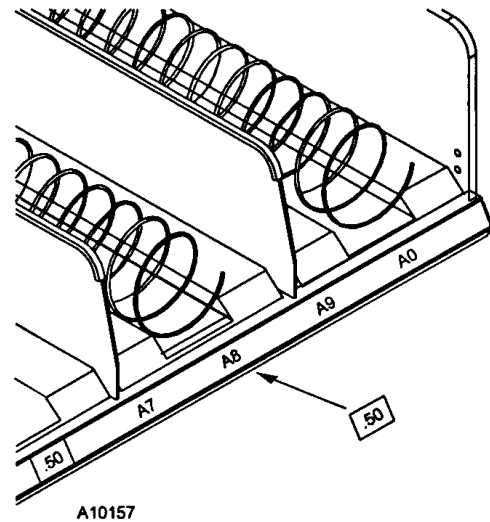

Figure 19. Price Labels

QUICK REFERENCE SERVICE COMMANDS:

VENDOR - PROGRAMMING INSTRUCTIONS

Press Service Mode Button on the Control Board and follow the steps outlined below:

MODE KEY	FUNCTION	TO PROGRAM ENTER THE FOLLOWING
1	DISPENSE COINS	[1] PLUS [A] = 25¢ [1] PLUS [B] = 10¢ [1] PLUS [C] = 5¢ [1] PLUS [D] = \$1.00
2	MOTOR COUNT	[2] = NUMBER OF ACTIVE MOTORS
3	DOWNWARD CONFIGURATION	[3] = RECONFIGURES MACHINE WITH ALL FUNCTIONAL MOTORS
4	ACCOUNTABILITY	[4] PLUS [A] = TOTAL SALES SINCE INITIALIZATION [4] PLUS [B] = TOTAL BILLS IN STACKER SINCE INITIALIZATION [4] PLUS [C] = TOTAL VENDS SINCE INITIALIZATION [4] PLUS [D] = TOTAL VENDS SINCE LAST RESET [4] PLUS [E] = RESET (RESETTABLE) TORALS – CONFIRM WITH [F] [4] PLUS [G] = FILL COINS IN COIN TUBES [4] PLUS [12] = "DEX/UCS" REPORT INFORMATION
5	SET PRICE - INDIVIDUAL SELECTION SET PRICE - ENTIRE ROW SET PRICE - ENTIRE MACHINE	[5] PLUS (SEL) PLUS (PRICE) PLUS [10] [5] PLUS (SEL) PLUS (PRICE) PLUS [11] [5] PLUS (SEL) PLUS (PRICE) PLUS [12]
6	TEST VEND - SINGLE SELECTION	[6] PLUS SELECTION
7	TEST VEND - ENTIRE ROW	[7] PLUS ROW "ALPHA" (PRESS & HOLD [13] TO ABORT)
8	TEST VEND - ENTIRE MACHINE	[8] (PRESS AND HOLD [13] TO ABORT ANY TIME DURING TEST)
9	EDIT POINT OF SALES MESSAGE	[9] PLUS MESSAGE - REFER TO SERVICE MANUAL
10	LANGUAGE SELECTION	[10] PLUS [A] = ITALIAN [10] PLUS [B] = DUTCH [10] PLUS [C] = SPANISH / ENGLISH [10] PLUS [D] = DANISH [10] PLUS [E] = ENGLISH [10] PLUS [F] = FRENCH / ENGLISH [10] PLUS [G] = GERMAN [10] PLUS [11] = AUXILIARY
11	VEND OPTIONS - BILL ESCROW VEND OPTIONS - FORCE VEND VEND OPTIONS - MAXIMUM CHANGE VEND OPTIONS - SET TIME & DATE VEND OPTIONS - TIMED SHUT DOWN VEND OPTIONS - ONE FREE PRODUCT VEND OPTIONS - PROMOTIONAL VEND VEND OPTIONS - CONTINUOUS TEST VEND	[11] PLUS [A] = BILL ESCROW "ON" OR "OFF" [11] PLUS [B] = FORCE VEND "ON" OR "OFF" [11] PLUS [C] PLUS (AMT) PLUS " [11] PLUS [D] (SEE SERVICE MANUAL) [11] PLUS [E] (SEE SERVICE MANUAL) [11] PLUS [F] (SEE SERVICE MANUAL) [11] PLUS [G] (SEE SERVICE MANUAL) [11] PLUS [12]+[12]+[12] = TEST VEND ALL CONFIGURED MOTORS

S
E
R
V
I
C
E

M
O
D
E

ELECTRICAL TROUBLESHOOTING

This flow chart indicates what should happen when power is applied to the vendor.

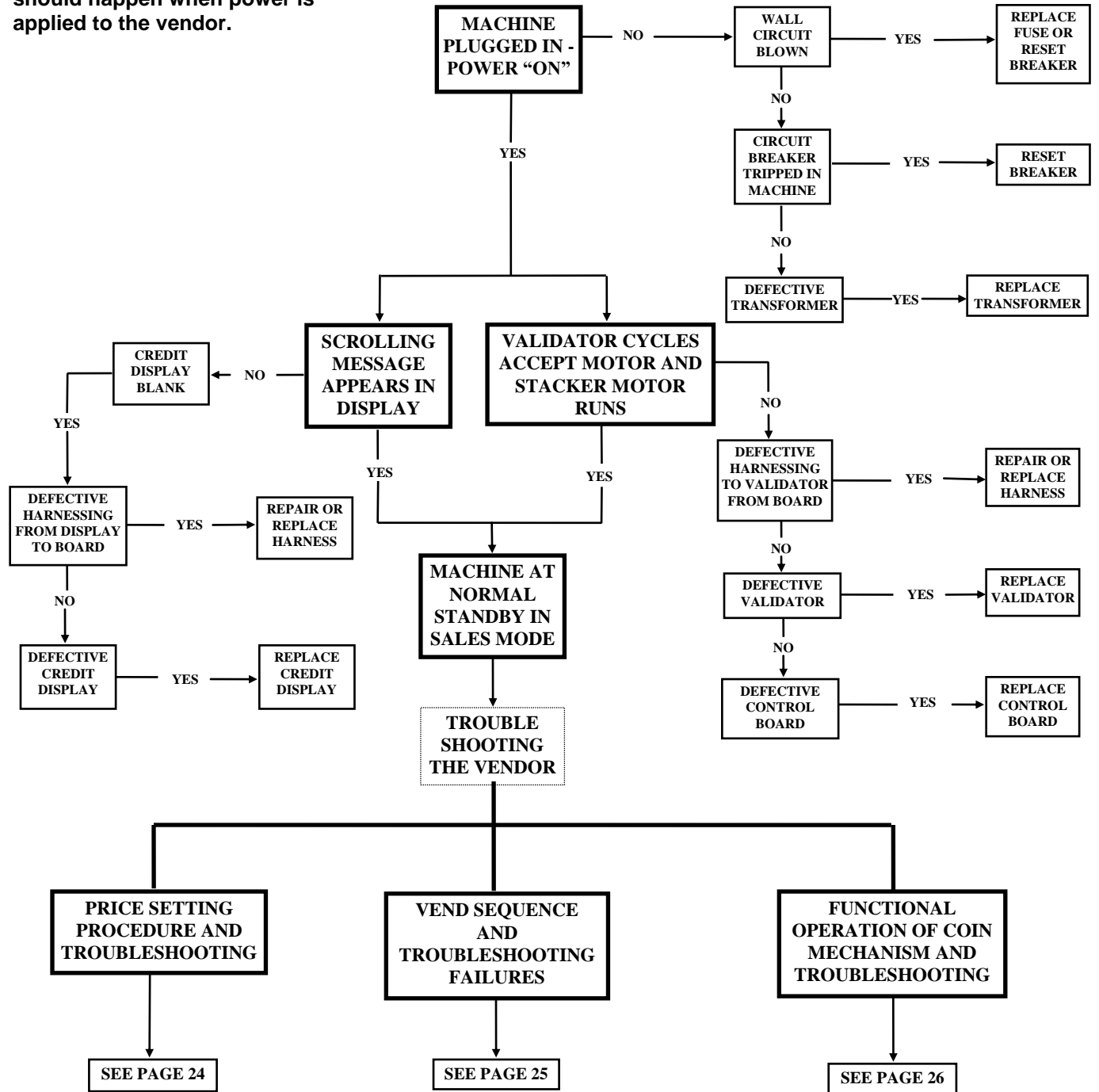

ELECTRICAL TROUBLESHOOTING

This flow chart indicates what should happen during the Price Setting Mode and gives troubleshooting hints for problems that could be encountered

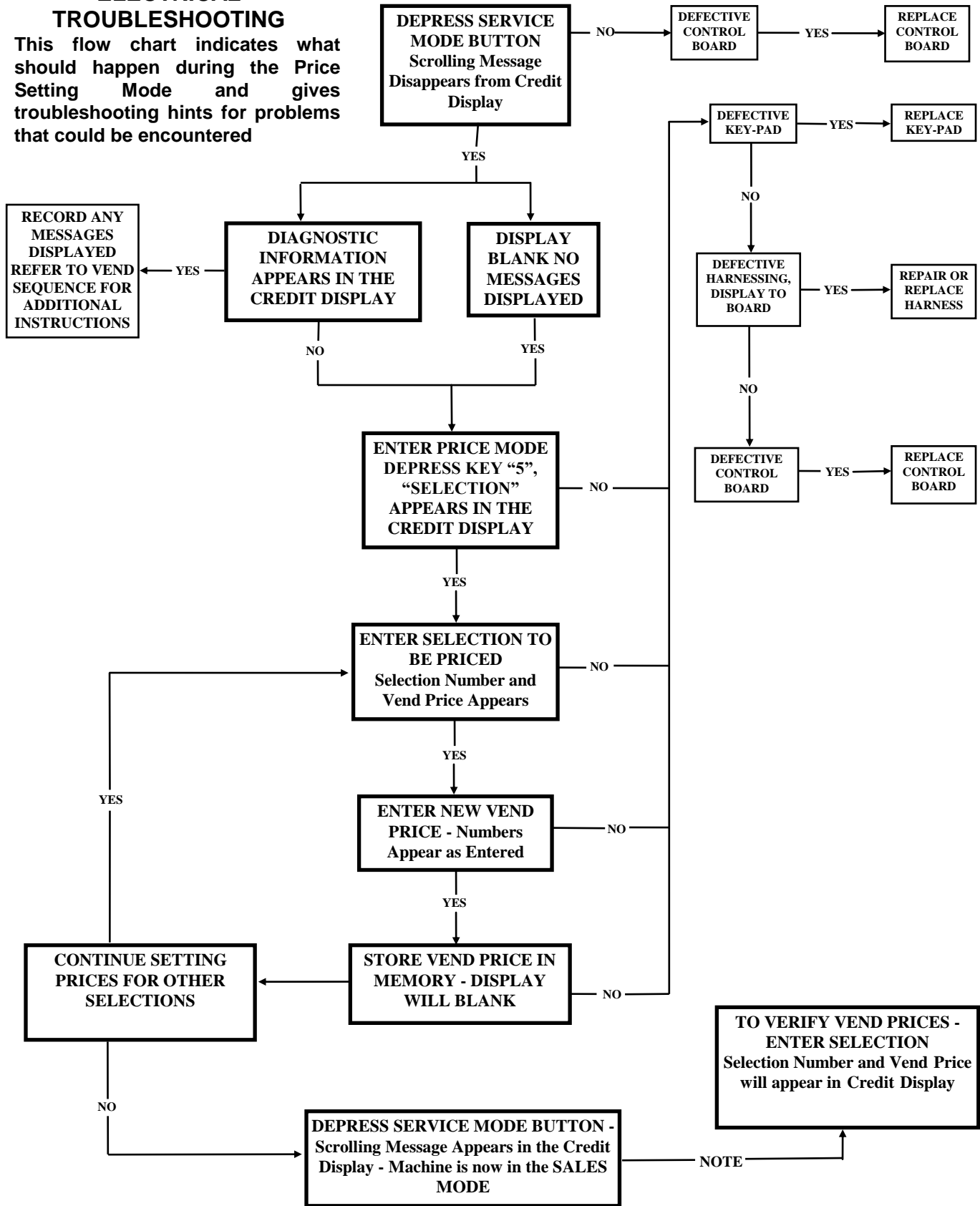

ELECTRICAL TROUBLESHOOTING

This flow chart explains the Vend Sequence and gives troubleshooting hints for problems that could occur during a Vend .

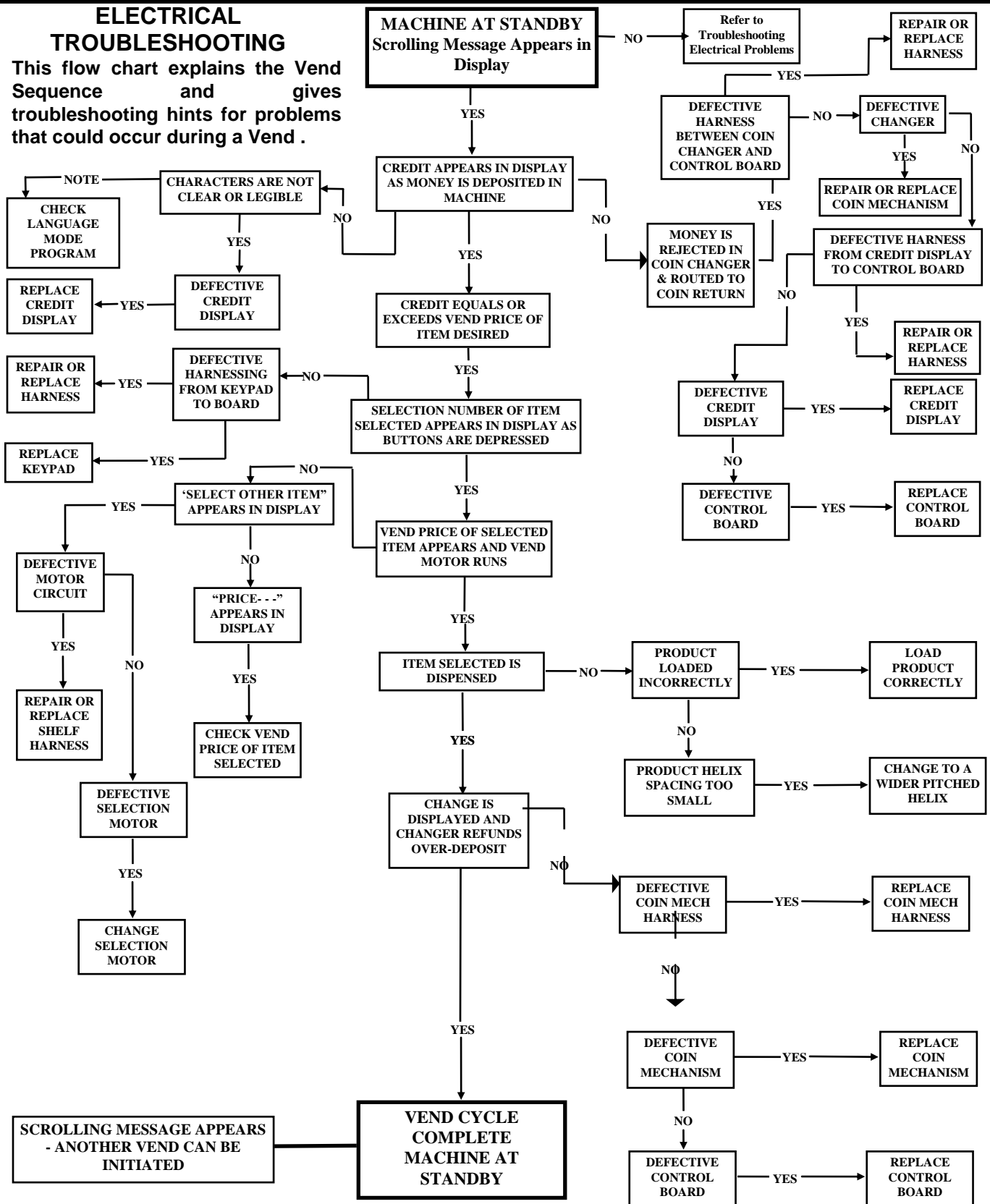

PRINTED CIRCUIT BOARD PIN-OUT

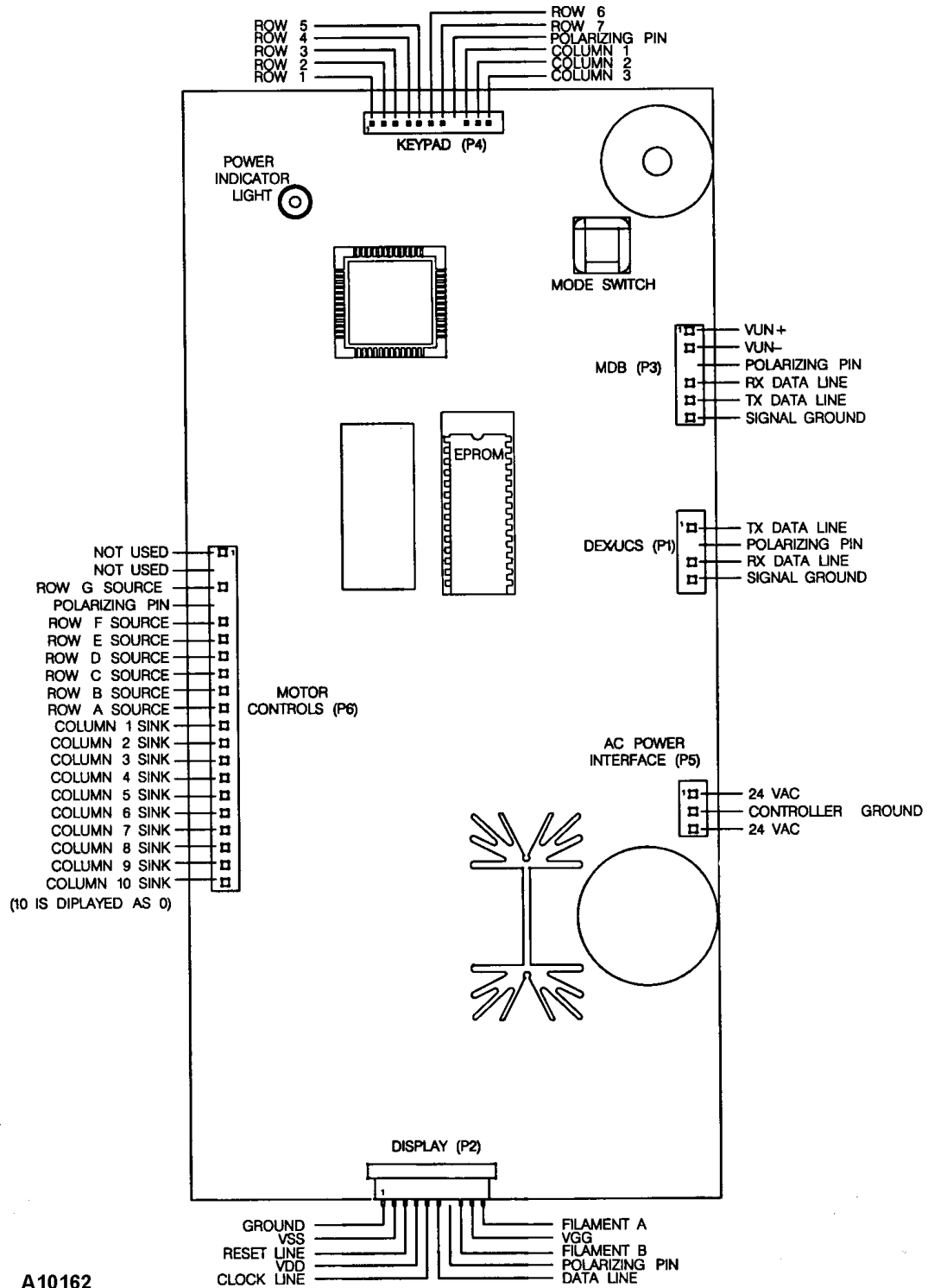

A10162

SCHEMATIC

