

**CD8 EC
ELECTRONIC CONTROL SYSTEM
COLD DRINK VENDOR
MODEL: 3037**

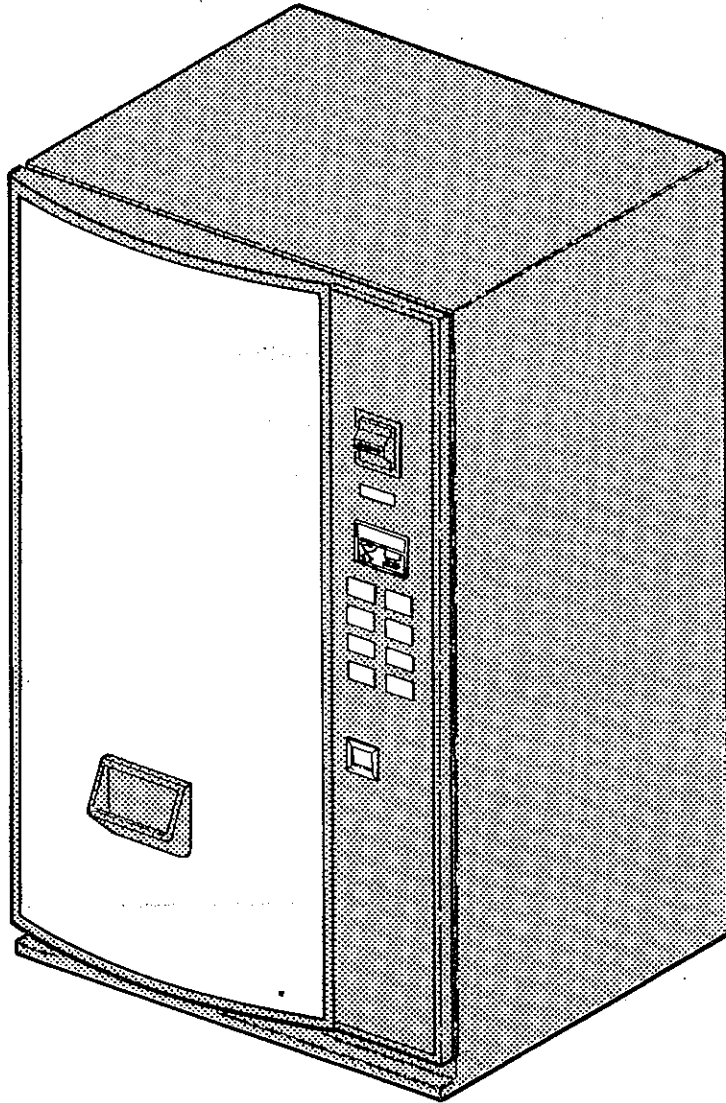

**SERVICE
MANUAL**

JULY 1995 REV. B

P/N 4202997

TABLE OF CONTENTS

<u>INTRODUCTION:</u>	3	<u>TOTAL VENDS:</u>	12
<u>SPECIFICATIONS:</u>	3	<u>REFRIGERATION TROUBLE-SHOOTING:</u>	14
<u>UNPACKING:</u>	3	<u>COLD CONTROL:</u>	16
<u>GROUNDING & ELECTRICAL:</u>	4	<u>TROUBLESHOOTING:</u>	17
<u>VOLTAGE CHECK:</u>	4	<u>CARE & CLEANING:</u>	18
<u>LABEL INSTALLATION:</u>	5	<u>OPERATION RECOMMENDATIONS:</u>	18
<u>LOADING INSTRUCTIONS:</u>	6	<u>PARTS ORDERING PROCEDURE:</u>	18
<u>PRICE SETTING INSTRUCTIONS:</u>	6		
<u>COIN MECHANISM:</u>	7		
<u>INSTALLATION CHECK LIST:</u>	8		
<u>SERVICE MODE FUNCTIONS:</u>	8		
<u>MOTOR COUNT:</u>	8		
<u>COIN DISPENSE:</u>	9		
<u>TEST VEND - INDIVIDUAL MOTORS:</u>	9		
<u>TEST VEND - ALL MOTORS:</u>	9		
<u>SET VEND PRICES:</u>	9		
<u>OPTIONS:</u>	10		
<u>FORCE VEND OPTION:</u>	10		
<u>BILL ESCROW:</u>	10		
<u>MULTI VEND:</u>	11		
<u>ALTERNATE VEND COLUMNS:</u>	11		
<u>ALTERNATE VEND 1, 2 & 3 COLUMNS:</u>	11		
<u>ALTERNATE VEND 5 & 6 COLUMNS:</u>	11		
<u>ALTERNATE VEND 7 & 8 COLUMNS:</u>	12		
<u>ALTERNATE VEND 9 & 10 COLUMNS:</u>	12		
<u>SLOW COIN PAYOUT:</u>	12		
<u>TOTAL CASH:</u>	12		

INTRODUCTION:

This service manual contains instructions, service and installation guidelines pertaining to the Model 3037 Can Drink Vendor. The model 3037 is an eight (8) select 12 ounce can vendor with two (2) pre-cool storage shelves on the inner door. Product is stored in serpentine columns, easily loaded, and routed to the 24 volt motor-driven ejector mechanisms and vended on a "first-in", "first-out" vend principle. The ejector mechanisms consist of a "dual" cam arrangement. The front cam holds the product to be vended at the "vend position", releasing it to the delivery area during the vend cycle. The rear cam is advanced into the path of the cans, in front of the second can, holding them back until the vend cycle is complete. At the end of the vend cycle the next can is released to the "vend position", awaiting the next vend.

The electronic control system provides the versatility to allow each selection to be priced individually, with vend prices ranging from \$.05 to \$99.95 in five-cent increments. The controller monitors electrical functions during

each vend and any malfunctions, (faulty motors, etc.) detected by the controller will be placed in memory and that selection will become in-operative. Individual selections determined in-operative do not affect the operation of the remaining selections.

SPECIFICATIONS:

SPECIFICATIONS:

72" High
42" Wide
32 1/2" Deep

ELECTRICAL:

115 Volt, 60 Hertz, 11.9 Amps

COINAGE:

Mars TRC6010 Coin Mech
Coinco 9302L Coin Mech

REFRIGERATION:

1/3 Horsepower
Refrigerant - R-134a
Charge - 7.5 Ounces

CAPACITY:

Eight (8) Selections
434 - 12 Oz. Cans in Vend Area
26 - 12 Oz. Cans in Pre-Cool

UNPACKING:

This machine has been thoroughly inspected before leaving the factory and the delivering carrier has accepted this vendor as their responsibility. Any damage or irregularities should be noted at the time of delivery and reported to the carrier. Request a written inspection report from the claims inspector to file any claim for damage. File the claim with the **CARRIER (NOT THE MANUFACTURER)** within 15 days after receipt of the machine.

Carefully remove the outside packaging material in a manner not to damage the finish or exterior of the machine. Inspect the machine for concealed shipping damage. Report any damage hidden by the packaging material

directly to the delivering carrier on a hidden damage report.

Record the model number and serial number of the vendor for your records. These numbers can be found on the Serial Plate located on the rear of the cabinet and/or inside the vendor. Refer to these numbers on all correspondence and inquiries pertaining to this vendor.

To minimize installation time and to avoid service problems due to improper installation, follow the instructions outlined in this manual. To remove the machine from the shipping pallet, follow the steps outlined below (**See Illustration #1**)

Position the vendor in its place of operation, no further than 4 feet from the power outlet or receptacle and check that the door will open fully without interference. Leave at least six (6) inches of space between the back of the machine and any wall or obstruction for proper air circulation. Level the vendor, making sure all levelers are touching the floor. The vendor **must** be level for proper operation.

Open the outer door and remove all internal packing material. On machines that are furnished with lock and keys, the keys to the vendor will be located in the coin return cup.

Consult local, state and federal codes and regulations before installation of the vendor.

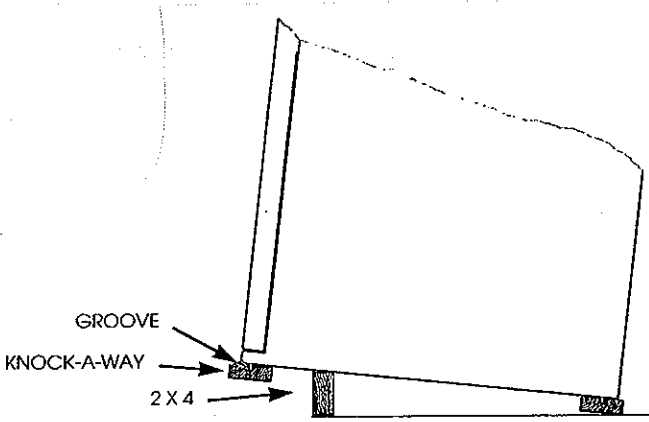

ILLUSTRATION #1

DO NOT OPERATE THIS VENDOR ON AN EXTENSION CORD

WARNING:

Do not block the ventilating screens in front or in the rear of the vendor. Always allow free ventilation behind a bank installation, so that exhaust air is not trapped. Failure to do so could result in a REFRIGERATION FAILURE.

GROUNDING & ELECTRICAL:

For proper operation of any equipment utilizing electronically controlled components, it is recommended that the equipment be placed on an isolated or dedicated "noise" free circuit, properly polarized and grounded. The circuit should be a minimum **20 Amp, 115 Volt AC, 60 cycle** power source

Shown in **Illustration #2** and **Illustration #3** are two (2) properly grounded and polarized wall outlets. **Illustration #2** is a three (3) wire grounding type wall outlet. **Illustration #3** is a two (2) wire outlet with a three (3) plug adapter in place.

NOTE:
The "HOT" side of the outlet should always be counter-clockwise from the "GROUND" terminal, with the ground terminal at the bottom. The "NEUTRAL" terminal will be clockwise from the "ground" terminal.

VOLTAGE CHECK:

1. **Voltage Check:** With a Volt-Meter set to check AC line voltage, insert one connector to the HOT terminal and the other connector to the NEUTRAL terminal. The volt-meter should indicate 103 to 126 Volts AC.
2. **Polarity and Ground Check;** With a Volt-Meter set to check AC line voltage, insert one connector to the HOT terminal and the other connector to the GROUND terminal. The volt-meter should indicate 103 to 126 Volts AC.
3. **Amperage Check;** At the fuse box or circuit breaker panel, locate the proper circuit, and ensure that the amperage reading of the fuse or breaker protecting the circuit, is a minimum of that specified in the vendor Service Manual or greater.

If you find that the receptacle is not properly grounded, or polarized, you should contact a licensed electrician to correctly polarize and/or ground the receptacle to ensure safe operation.

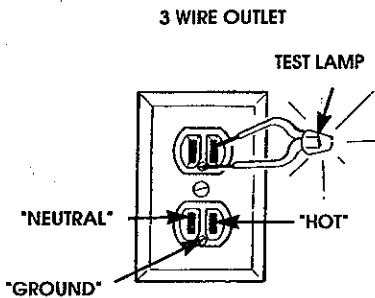

ILLUSTRATION #2

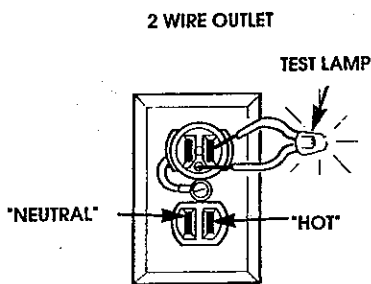

ILLUSTRATION #3

Locate the power switch in the lower left corner of the door, with the door open, and switch it to the "ON" position. The following should happen:

1. The display light will come on.
2. "USE CORRECT CHANGE" LED will light in the readout.
3. "MAKE ANOTHER SELECTION" LED will light in the readout.
4. Validator stacker, if so equipped, will cycle.
5. The evaporator motors and refrigeration unit will run.
6. A decimal point (.) and two (2) zeros will appear in the credit display.

LABEL INSTALLATION:

Selection identification labels for the buying customer are to be placed inside the selection button. Open the outer door and separate the inner door from the outer door. On the back side of the outer door, locate and open the coin mech door by sliding the latch at the top to the right. Insert the Selection Label into the pocket provided as shown in **Illustration #4**. Make sure the label agrees with the product loaded in the serpentine column.

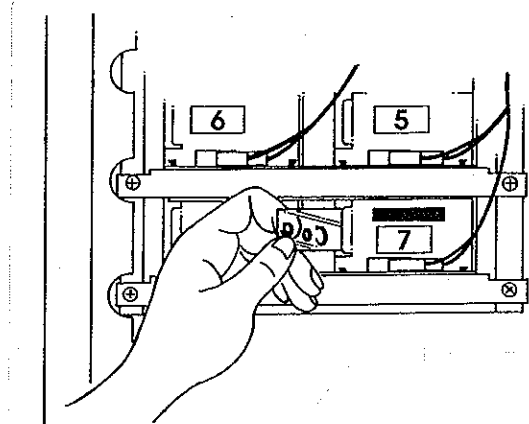

ILLUSTRATION #4

Tabs are provided at the loading point of each selection. Selection numbers are also provided. Make sure that this label also coincides with the label in the selection button and agrees with the product in the serpentine column. See **Illustration #5**.

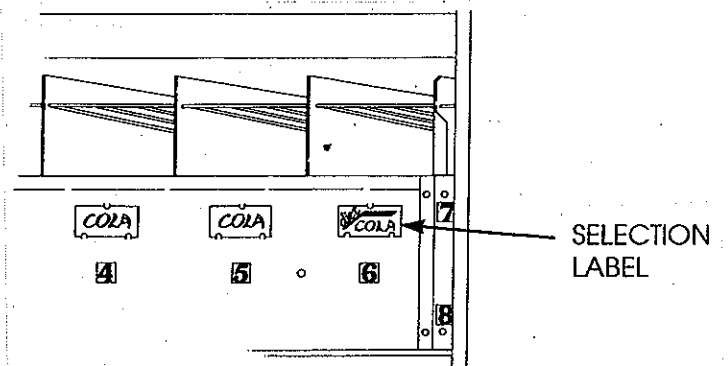

ILLUSTRATION #5

LOADING INSTRUCTIONS:

The serpentine columns are numbered from left to right when facing the vendor. There are eight (8) 12 ounce selections in the vendor, with two (2) pre-cool shelves on the back of the inner door. Selections 1 through 6 will hold approximately sixty (61) cans. Selection #7 will hold Thirty three (33) cans and selection #8 will hold thirty five (35) can. Each pre-cool shelf will hold thirteen (13) cans.

To load the serpentine columns, place the product in the top shelf and release as shown in **Illustration #6** & **Illustration #7**. Make sure that the product being loaded and the rack number coincides with the Selection Label located in the selection button.

The pre-cool shelves should be used to store the "high volume" flavors, (usually Cola and Diet Cola). The cans in the pre-cool shelves should be used first when reloading. This will help guard against the sale of warm drinks.

Do not load dented or damaged cans in the serpentine columns. Possible jams could occur. Do not let the first can being loaded strike the cams on the ejector mech with full force.

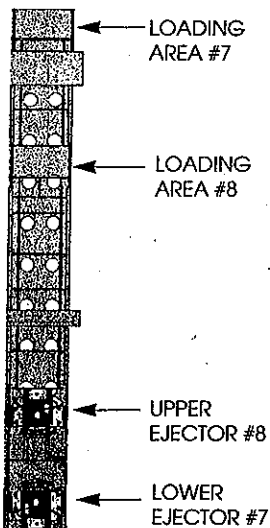

ILLUSTRATION #7

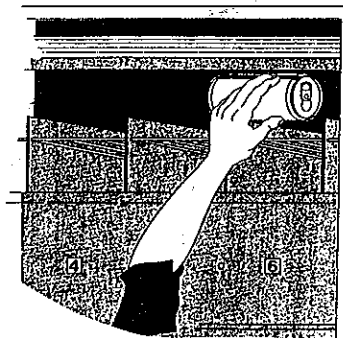

ILLUSTRATION #6

PRICE SETTING INSTRUCTIONS:

All vend prices are controlled by the controller. A vend price must be established for each selection. The procedure for re-programming or changing the vend prices is as follows:

1. Open vendor and separate the inner and outer doors.
2. Locate the **Service Mode Button** on the inside upper portion of the outer door. See **Illustration #8**

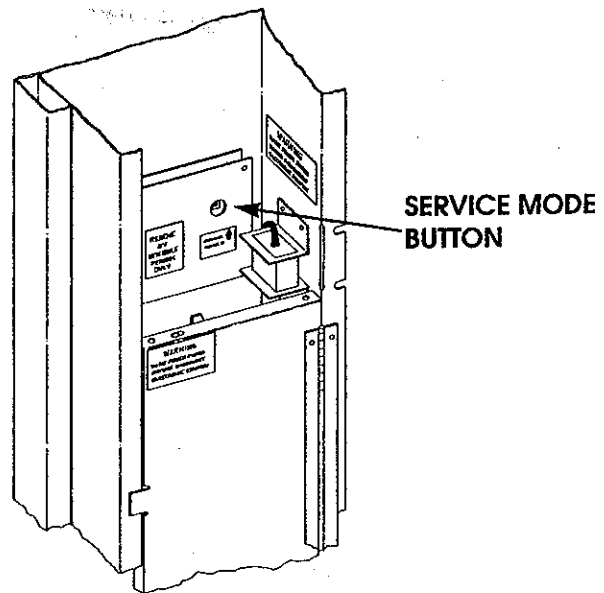

ILLUSTRATION #8

3. Push the "Service Mode Button" **five times (5)**. The display on the front of the door will read **Spr**.
4. Push the selection button of the item to be priced. See **Illustration #9** The current vend price for that selection will be displayed.
5. Depressing the same selection button a second time **Increases** the vend price in \$.05 increments at the rate of \$.05 every

half second as long as the button is held depressed.

6. Depressing the same selection button a third time **Decreases** the vend price in \$.05 decrements at the rate of \$.05 every half second as long as the button is held depressed.
7. Continued depressing the selection button alternates between **Increasing** and **Decreasing** the vend price of that selection. See **Illustrations #9 & #10**

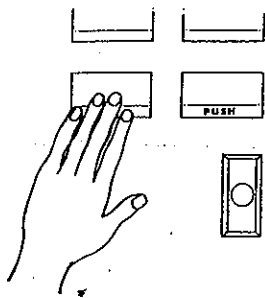

ILLUSTRATION #9

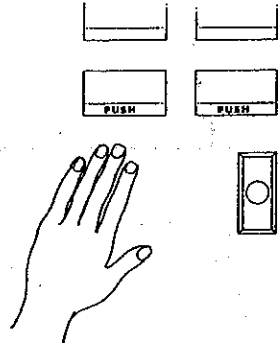

ILLUSTRATION #10

8. When the desired vend price for that selection appears in the display, the price for that selection is "set", go to the next selection.

Setting the vend price at **\$.00** will set that particular selection at "Free Vend" and no money is required to dispense the product when the machine is in the "Sales Mode". To exit to the "Sales Mode", press the "Service Mode Switch". The controller will automatically exit to the "Sales Mode" in approximately 20 seconds if no button is depressed during that time.

IMPORTANT:

Make sure that the vend price is correct for each selection. Make sure that the price, selection label and product loaded in each serpentine agrees.

COIN MECHANISM:

Load the coin changer with nickels, dimes and quarters. When adequate nickels have been loaded to cover the "low level sensors" in the nickel tube, the "USE CORRECT CHANGE" LED will go off. The following coin changers can be used:

MARS TRC6010
COINCO 9302L

Coins inserted will be stored in self-loading, high capacity change tubes and coins returned on over deposit will be the least number of coins available. When the change tubes become full, coins deposited will be routed to the cash box. The following chart indicates the approximate capacity of each of the coin tubes.

COIN TUBE CAPACITY				
	5¢	10¢	25¢ OPTION	
			HI 25¢	LOW 25¢
FULL LEVEL	68-69	98-99	66-67	8-9
LOW LEVEL	7-8	10-11	8-9	8-9

To empty the coins stored in the change tubes, push the "Service Mode Switch" two (2) times. CPO will appear in the display.

Selection Button #1 will dispense nickels.
Selection Button #2 will dispense dimes
Selection Button #3 will dispense quarters.

NOTE:

If the vendor is equipped with a Dollar Bill Validator, the coin mechanism **must** have a minimum of nickels and quarters to cover the "low level" sensors to allow the validator to function. Refer to chart above.

INSTALLATION CHECK LIST:

1. All shipping brackets, packing material and tape has been removed.
2. Make sure the vendor is level from front to back and right to left.
3. The dedicated outlet is properly polarized and grounded.
4. Coin Mechanism has been properly loaded and switches have been set properly.
5. All vend prices have been set correctly.
6. The vendor has been properly loaded and all items in each selection corresponds to the label and vend price.

7. The machine is plugged directly into a live 115 volt dedicated outlet.

NOTE:

EXTENSION PROBLEMS, DO NOT USE	CORDS	CAUSE
---	--------------	--------------

8. The machine has at least six (6) inches of space behind it.
9. Soft drinks have been pre-cooled.
10. The door to the vendor is closed tightly and locked.

SERVICE MODE FUNCTIONS:

Eight different programs or modes can be accessed within the controller. Different functions can be performed once each mode is accessed. Depressing the "Service Mode" Switch will advance the controller to the various modes. The following indicates the various modes available.

1. MOTOR COUNT
2. COIN DISPENSE
 1. NICKEL PAYOUT
 2. DIME PAYOUT
 3. QUARTER PAYOUT
3. TEST VEND SINGLE SELECTION
4. TEST VEND ALL SELECTIONS
5. SET PRICE
6. OPTIONS
 1. FORCE VEND
 2. BILL ESCROW
 3. MULTI VEND
 4. ALTERNATE VEND 1, 2 & 3 COLUMNS
 5. ALTERNATE VEND 5 & 6 COLUMNS
 6. ALTERNATE VEND 7 & 8 COLUMNS
 7. NOT APPLICABLE
 8. SLOW COIN PAYOUT
7. TOTAL CASH SALES
8. TOTAL VEND COUNT

MOTOR COUNT:

Pressing the Mode Switch **one time** the controller will be in the "Motor Count" mode. The number of functional motors will be displayed.

If a "5" followed by a dash and two digits is flashing in the display, a selection button is stuck in the "ON" position.

EXAMPLE:

"5-03" and "5-12" flashing alternately would indicate that buttons 3 and 12 are stuck in the "ON" position. **The service mode functions will not respond properly until the "stuck button" condition has been corrected.**

If the display shows two (2) digits, not flashing, (**EXAMPLE: "08"**) this indicates the number of functional motors in the machine. If any number other than "08" is displayed, test vend all motors to determine the faulty selections.

If no other functions are to be performed in the "Service Mode", to exit and return to the "Sales Mode", press the mode switch until ".00" appears in the display. The controller will

automatically return to the sales mode after approximately 20 seconds of inactive service mode time.

COIN DISPENSE:

Pressing the "Mode Switch" **two times** places the controller in the "**Coin Dispense**" mode. "**CPO**" will appear in the display. Coins can be removed from the storage tubes in the Coin Changer.

- Selection Button #1 - dispenses nickels
- Selection Button #2 - dispenses dimes
- Selection Button #3 - dispenses quarters

Pressing the "Mode Switch" will exit the Service Mode and return the controller to the "Sales Mode". The controller will automatically return to the sales mode after approximately 20 seconds of inactive service mode time.

TEST VEND - INDIVIDUAL MOTORS:

Pressing the "Mode Switch" **three times** places the controller in the **single** or individual **motor test** mode. "**DTS**" will appear in the display.

Press any of the selection buttons to run the corresponding motor. If the selection is functional the motor will run. The selection number will be shown in the display. At the end of the test "**DTS**" will appear. If the motor is inoperative, "**FAIL**" will be displayed in the readout. Test vending of individual motors can be repeated by pushing other selection buttons.

Pressing the "Mode Switch" will exit the Service Mode and return the controller to the "Sales Mode". The controller will automatically return to the sales mode after approximately 20 seconds of inactive service mode time.

TEST VEND - ALL MOTORS:

Pressing the "Mode Switch" **four times** places the controller in the **test "all" motors** mode. "**DTA**" will appear in the display.

Pressing any selection button will start the test. The motors will be ran in sequence, starting with motor #1. As the motors are being run, the selection number will appear in the display. At the end of the test "**DTA**" will appear. If the motor is inoperative, "**FAIL**" will be displayed in the readout.

Pressing the "Mode Switch" will exit the Service Mode and return the controller to the "Sales Mode". The controller will automatically return to the sales mode after approximately 20 seconds of inactive service mode time.

SET VEND PRICES:

Pressing the "Mode Switch" **five times** places the controller in the "**Set Price**" mode. "**SPR**" will appear in the display

1. Push the selection button of the item to be priced. See **Illustration #9** The current vend price for that selection will be displayed.
2. Depressing the same selection button a second time **Increases** the vend price in \$.05 increments at the rate of \$.05 every half second as long as the button is held depressed.
3. Depressing the same selection button a third time **Decreases** the vend price in \$.05 decrements at the rate of \$.05 every half second as long as the button is held depressed.
4. Continued depressing the selection button alternates between **Increasing** and **Decreasing** the vend price of that selection. See **Illustrations #9 & #10**
5. When the desired vend price for that selection appears in the display, the price for that selection is "set", go to the next selection.

Setting the vend price at **\$.00** will set that particular selection at "Free Vend" and no money is required to dispense the product when the machine is in the "Sales Mode".

IMPORTANT:

Make sure that the vend price is correct for each selection. Make sure that the price, selection label and product loaded in each serpentine agrees.

Pressing the "Mode Switch" will exit the Service Mode and return the controller to the "Sales Mode". The controller will automatically return to the sales mode after approximately 20 seconds of inactive service mode time.

OPTIONS:

Pressing the "Mode Switch" **six times** places the controller in the "Options" mode. "OPT" will appear in the display. Pressing selection button #1 allows you to scroll through the options that are available. The following is a list of options within this mode along with the combination of numbers that will be displayed as you scroll through the option mode.

- 1= FORCE VEND
- 2= BILL ESCROW
- 3= MULTI VEND
- 4= ALTERNATE VEND 1, 2 & 3 COLUMNS
- 5= ALTERNATE VEND 5 & 6 COLUMNS
- 6= ALTERNATE VEND 7 & 8 COLUMNS
- 7= ALTERNATE VEND 9 & 10 COLUMNS
- 8= SLOW COIN PAYOUT

FORCE VEND OPTION:

When in the Options Mode, pressing selection button #1 **one time** the controller will advance to the "Force Vend" Mode. The display will indicate the current setting.

- 1-1 = FORCE VEND "ON"
- 1-0 = FORCE VEND "OFF"

When the "Force Vend "ON" Mode" is selected the controller will force the buying customer to make a purchase when a dollar bill is inserted, overriding the "coin return" command. When in the "Force Vend "ON" Mode", coin return on 5¢, 10¢ and 25¢ coins is not affected. When in "Force Vend "OFF" Mode" the controller will allow the buying customer to receive change from a dollar bill insertion when the coin return button is pressed. A purchase is not necessary.

Press Selection Button #6 to change from "OFF" to "ON" or from "ON" to OFF".

Pressing the "Mode Switch" will exit the Service Mode and return the controller to the "Sales Mode". The controller will automatically return to the sales mode after approximately 20 seconds of inactive service mode time.

BILL ESCROW:

This mode would be used if the Validator being used has an "Escrow" feature. When in the Options Mode, pressing selection button #1 **two times** the controller will advance to the "Bill Escrow" Mode. The display will indicate the current setting.

- 2-1 = "ON"
- 2-0 = "OFF"

When the "Bill Escrow "ON" Mode" is selected the controller will return the last bill inserted to the buying customer when the coin return button is depressed. When in "Bill Escrow

"OFF" Mode" the controller will allow the buying customer to receive change from a dollar bill insertion when the coin return button is pressed. A purchase is not necessary.

Press Selection Button #6 to change from "OFF" to "ON" or from "ON" to OFF".

NOTE:

If the "Force Vend "ON" Mode has been selected, a purchase has to be made on a dollar bill insertion. The "Coin Return" feature has been disabled.

Pressing the "Mode Switch" will exit the Service Mode and return the controller to the "Sales Mode". The controller will automatically return to the sales mode after approximately 20 seconds of inactive service mode time.

MULTI VEND:

When in the Options Mode, pressing selection button #1 **three times** the controller will advance to the "**Multi Vend" Mode**. The display will indicate the current setting.

- 3-1 = "ON"
- 3-0 = "OFF"

When in the "Multi Vend "ON" Mode", multiple vends can be selected as long as adequate credit is available. When in this mode, to receive change on over deposit, the "Coin Return" button must be pushed.

When in the "Multi Vend "OFF" Mode the controller is set to a single selection vend mode, or normal operation. Change will be returned immediately if the established credit exceeds the vend price each time a vend is completed.

Press Selection Button #6 to change from "OFF" to "ON" or from "ON" to OFF".

Pressing the "Mode Switch" will exit the Service Mode and return the controller to the "Sales Mode". The controller will automatically return to the sales mode after approximately 20 seconds of inactive service mode time.

ALTERNATE VEND COLUMNS:

This feature allows the owner/operator to "tie" two or more columns together for "high volume" flavors. When in the "alternate" mode and an empty column is selected, an item will be dispensed from the alternate selection.

EXAMPLE:

If Selections 1 & 2 are placed in the alternate mode and column 2 is empty, an item would be dispensed from column 1 when selection button #2 is pressed.

Press Selection Button #6 to change the settings.

Pressing the "Mode Switch" will exit the Service Mode and return the controller to the "Sales Mode". The controller will automatically return to the sales mode after approximately 20 seconds of inactive service mode time.

ALTERNATE VEND 1, 2 & 3 COLUMNS:

When in the "Options Mode", pressing selection button #1 **four times** the controller will advance to the "**Alternate vend 1, 2 & 3 Columns Mode**. The display will indicate the current setting.

- 4-1 = ALTERNATE "OFF"
- 4-2 = ALTERNATE 1 & 2
- 4-3 = ALTERNATE 1, 2 & 3

Press Selection Button #6 to change the settings.

ALTERNATE VEND 5 & 6 COLUMNS:

When in the "Options Mode", pressing selection button #1 **five times** the controller will advance to the "**Alternate vend 5 & 6 Columns Mode**. The display will indicate the current setting.

- 5-1 = ALTERNATE "OFF"
- 5-2 = ALTERNATE 5 & 6

Press Selection Button #6 to change the settings.

ALTERNATE VEND 7 & 8 COLUMNS:

When in the "Options Mode", pressing selection button #1 **six times** the controller will advance to the "Alternate vend 7 & 8 Columns Mode. The display will indicate the current setting.

- 6-1 = ALTERNATE "OFF"
- 6-2 = ALTERNATE 7 & 8

Press Selection Button #6 to change the settings.

ALTERNATE VEND 9 & 10 COLUMNS:

When in the "Options Mode", pressing selection button #1 **seven times** the controller will advance to the "Alternate vend 9 & 10 Columns Mode. The display will indicate the current setting.

- 7-1 = ALTERNATE "OFF"
- 7-2 = ALTERNATE 9 & 10

Press Selection Button #6 to change the settings.

SLOW COIN PAYOUT:

Use this option only if a **Maka** Coin Changer is being used. When in the Options Mode, pressing selection button #1 **six times** the controller will advance to the "**Slow Coin Payout Mode**". The display will indicate the current setting.

- 8-1 = "ON"
- 8-0 = "OFF"

Press Selection Button #6 to change the settings. If a changer other than a Maka is used, make sure the setting is at "8-0".

TOTAL CASH:

Pressing the "Mode Switch" **seven times** the controller will display the total cash that has been accumulated. The display will flash 2 numbers and then 5 numbers.

EXAMPLE:

02 316.80: this would indicate that a total of \$2316.80 had been accumulated in the vendor.

TOTAL VENDS:

Pressing the "Mode Switch" **eight times** the controller will display the total vends that has been accumulated. The display will flash 2 numbers and then 4 numbers.

EXAMPLE:

04 9150: this would indicate that a total of 49,150 vends had been accumulated in the vendor.

SERVICE MODE - PROGRAMMING INSTRUCTIONS

***** SERVICE MODE FUNCTIONS *****

- 1) PRESS THE YELLOW MODE BUTTON LOCATED ON THE CONTROL BOARD INSIDE THE DOOR BELOW THE BILL VALIDATOR.
- 2) LOOK AT THE DISPLAY WINDOW LOCATED ABOVE THE COIN INSERT ON THE FRONT OF THE MACHINE DOOR
3. IF A 5 FOLLOWED BY A DASH AND TWO DIGITS IS FLASHING IN THE DISPLAY, A SELECTION BUTTON IS STUCK "ON".
EXAMPLE: "5-03" FLASHING TELLS YOU THAT BUTTON 3 IS STUCK. SERVICE MODE FUNCTIONS WILL NOT RESPOND UNTIL THIS CONDITION IS CORRECTED.
 OTHERWISE, THE DISPLAY SHOWS 2 DIGITS - THIS IS THE NUMBER OF FUNCTIONAL MOTORS IN THE MACHINE
4. THE CONTROL BOARD WILL AUTOMATICALLY RETURN TO "SALES MODE" AFTER APPROXIMATELY 20 SECONDS OF INACTIVE SERVICE MODE TIME.
5. MACHINE IS IN "SALES MODE" WHEN ".00" CAN BE SEEN IN THE DISPLAY.

MOTOR COUNT	PRESS MODE BUTTON	NUMBER OF FUNCTIONAL MOTORS WILL BE DISPLAYED - SEE NOTES ABOVE
DISPENSE COINS	PRESS MODE BUTTON 2 TIMES	(CPO") APPEARS IN DISPLAY SELECTION BUTTON 1 - DISPENSE NICKELS SELECTION BUTTON 2 - DISPENSE DIMES SELECTION BUTTON 3 - DISPENSE QUARTERS PRESS MODE BUTTON TO EXIT SERVICE MODE
TO TEST VEND INDIVIDUAL MOTORS	PRESS MODE BUTTON 3 TIMES	(DTS") APPEARS IN DISPLAY PRESS A SELECTION BUTTON TO RUN THE CORRESPONDING MOTOR. PRESS MODE BUTTON TO EXIT SERVICE MODE
TO TEST VEND ALL MOTORS	PRESS MODE BUTTON 4 TIMES	(DTA") APPEARS IN DISPLAY PRESS A SELECTION BUTTON - ALL MOTORS WILL RUN IN SEQUENCE. PRESS MODE BUTTON TO EXIT SERVICE MODE
TO SET VEND PRICES	PRESS MODE BUTTON 5 TIMES	(SPR") APPEARS IN DISPLAY PRESS AND RELEASE ANY SELECTION BUTTON - VEND PRICE IS DISPLAYED PRESS AGAIN TO INCREASE - PRESS AGAIN TO DECREASE WHEN DESIRED PRICE APPEARS - GO TO THE NEXT SELECTION PRESS MODE BUTTON TO EXIT SERVICE MODE
TOTAL CASH SALES	PRESS MODE BUTTON 7 TIMES	THE DISPLAY WILL FLASH 2 DIGITS THEN 4 DIGITS EXAMPLE: 02 - 316.80 WOULD BE \$2,316.80
TOTAL VEND COUNT	PRESS MODE BUTTON 8 TIMES	THE DISPLAY WILL FLASH 2 DIGITS THEN 4 DIGITS EXAMPLE: 04 - 9150 WOULD BE 49,150
TO SET FORCED VEND OPTION	PRESS MODE BUTTON 6 TIMES	(OPT") APPEARS IN DISPLAY PRESS BUTTON #1 UNTIL "1-1" OR "1-0" APPEARS IN DISPLAY. "1-1" = "ON" "1-0" = "OFF" PRESS BUTTON #6 TO CHANGE - PRESS MODE BUTTON TO EXIT SERVICE MODE
TO SET BILL ESCROW	PRESS MODE BUTTON 6 TIMES	(OPT") APPEARS IN DISPLAY PRESS BUTTON #1 UNTIL "2-1" OR "2-0" APPEARS IN DISPLAY. "2-1" = "ON" "2-0" = "OFF" PRESS BUTTON #6 TO CHANGE - PRESS MODE BUTTON TO EXIT SERVICE MODE
TO SET MULTI-VEND	PRESS MODE BUTTON 6 TIMES	(OPT") APPEARS IN DISPLAY PRESS BUTTON #1 UNTIL "3-1" OR "3-0" APPEARS IN DISPLAY. "3-1" = "ON" "3-0" = "OFF" PRESS BUTTON #6 TO CHANGE - PRESS MODE BUTTON TO EXIT SERVICE MODE
TO SET ALTERNATE 1,2 & 3	PRESS MODE BUTTON 6 TIMES	(OPT") APPEARS IN DISPLAY PRESS BUTTON #1 UNTIL "4-1", "4-2" OR "4-3" APPEARS IN DISPLAY "4-1" = ALTERNATE OFF "4-2" = ALTERNATE 1 & 2 "4-3" = ALTERNATE 1, 2 & 3 PRESS BUTTON #6 TO CHANGE - PRESS MODE BUTTON TO EXIT SERVICE MODE
TO SET ALTERNATE 5 & 6	PRESS MODE BUTTON 6 TIMES	(OPT") APPEARS IN DISPLAY PRESS BUTTON #1 UNTIL "5-1" OR "5-2" APPEARS IN DISPLAY "5-1" = ALTERNATE OFF "5-2" = ALTERNATE 5 & 6 PRESS BUTTON #6 TO CHANGE - PRESS MODE BUTTON TO EXIT SERVICE MODE
TO SET ALTERNATE 7 & 8	PRESS MODE BUTTON 6 TIMES	(OPT") APPEARS IN DISPLAY PRESS BUTTON #1 UNTIL "6-1" OR "6-2" APPEARS IN DISPLAY "6-1" = ALTERNATE OFF "6-2" = ALTERNATE 7 & 8 PRESS BUTTON #6 TO CHANGE - PRESS MODE BUTTON TO EXIT SERVICE MODE
TO SET SLOW COIN PAYOUT	PRESS MODE BUTTON 6 TIMES	USE THIS OPTION ONLY IF A MAKA COIN CHANGER IS USED PRESS BUTTON #1 UNTIL "8-1" OR "8-0" APPEARS IN DISPLAY "8-1" = "ON" "8-0" = "OFF" PRESS BUTTON #6 TO CHANGE - PRESS MODE BUTTON TO EXIT SERVICE MODE

REFRIGERATION TROUBLE-SHOOTING:

Know and understand how to service the unit and how they operate. Units may vary, but the operation is basically the same. Never guess at the problem, find the symptom before attempting any repair.

I. Compressor will not start

A. Voltage (Check to see if compressor has power)

1. Tripped breaker or blown fuse
2. Wall outlet faulty
3. Short or tear in power cord
4. Faulty cold control

a) Unplug power supply, remove screws from thermostat. Use a jumper wire, or place a screw through terminals; then restore power and check to see if the unit runs

5. Check for improper wiring

II. Compressor trips on Overload

A. Improper voltage (115 VAC Normal)

- 5-10% above, 5% below

B. Overload defective

- See VIII, B

C. Relay defective

- See VIII, C

D. Compressor defective

- See VIII, D

E. Short in other component

- Isolate and eliminate each electrical component until short is found

F. Compressor is too hot

1. Dirty condenser

NOTE:

Condenser must be kept clean of dirt and debris to allow for proper air circulation

2. Faulty condenser motor or blade

3. Restricted air flow

III. Noisy or vibrating unit

A. Components rubbing or touching each other

1. Check fan blades and motor
2. Loose shrouds and harness
3. Copper tubing
4. Loose or unsecured parts

B. Grommets

1. Worn, aged

C. Compressor

1. Bad Valves
2. Slugging
3. Bad windings (See **Schematic #1**)

D. Relay

1. Frozen in start position (See **Schematic #1**)

E. Low voltage

IV. Unit short cycles

A. Cold Control

1. Differential set too close

2. Probe in wrong area (i.e., touching evaporator or other metal)

- b. Check for oil around brazed connections

V. Unit operates long or continuously

A. Thermostat faulty

B. Air flow restricted

1. Faulty evaporator motor or blades causing coils to ice over
2. Air flow blocked by product in front of evaporator

C. Gasket leak

D. Excessive load

1. After loading, unit will run longer to pull out excessive heat from product.

E. Shortage of refrigerant or restriction

VI. Refrigerated space too warm

A. Restricted evaporator space

1. Evaporator motor or blades faulty. This causes the coils to ice over the evaporator.

2. Condenser air flow restricted

- a) Plugged or dirty condenser
- b) Condenser motor or blades bad
- c. Blade stuck

3. Condensing space restricted

- a) Unit placed too close to a wall

4. Compressor - bad valves

- a) Cap tube will start frosting 8 to 10 inches past evaporator connection tube

6. Thermostat improperly set

VII. 90% of all Refrigeration Problems are Electrical

A. Rules for breaking into a sealed hermetic system:

1. **DON'T!** This system has was not meant to be worked on outside the Factory Service Center

2. The four things that can go wrong with a sealed system and should be repaired at the Factory Service Center are:

a.) **Low Charge** - Low charges are caused usually by leaks; look for oil around seals and welds. Unit will not seal properly.

b) **Restriction in Systems (unit frost, then melts)** - not cooling properly, low side in vacuum

c) **Bad valves** - unit does not cool properly; noisy compressor

3. **REMEMBER, DO NOT** break into a sealed system for any reason - send the unit to the Factory Service Center

VIII. Trouble-Shooting unit circuits using OHM-Volt Meter

A. Using volt meter, check power source

B. Check Overload (**NOTE:** power must be off and fan circuit open)

1. Using Ohm meter, check terminals 1 and 3 for continuity. If no continuity is measured (0 Ohms), overload may be tripped. Wait 10 minutes and try again. If still no continuity, overload is defective.

C. Checking Relay (See Schematic #1)

1. Unscrew lead terminals and remove relay from compressor. (NOTE: keep relay upright)
2. Check terminals 1 and S, or L and S, replace relay if there is continuity
3. Check terminals 1 and M, or L and M, replace relay if there is no continuity.

D. Checking compressor (See Schematic #1)

1. Check winding resistance with Ohm meter
2. If readings are not within 2 Ohms, compressor is faulty.

COLD CONTROL:

ATTENTION:

Setting the cold control to a higher number will not cause drinks to cool faster. Setting the cold control too high will cause soft drinks to freeze.

These recommended cold settings are based on an average temperature outside the cabinet to supply the maximum cooling for the inside product. The recommended temperature for soft drinks is approximately 38°.

WARNING:

Wiring diagrams must be followed as shown. Any miswiring can cause serious electrical hazard and potential damage or rupture component electrical parts

WINDING RESISTANCE:

Approximate Resistance Reading Across Terminals - Use RXI SCALE

- COMMON to START: 12 Ohms
- COMMON to RUN: 2 Ohms
- RUN to START: 14 Ohms
- COMMON to SHELL: No Continuity

COLD CONTROL SETTING	AVERAGE ROOM TEMPERATURE
1	
2	65°F to 85°F
3	85°F to 110°F
4	
5	over 110°F
6	

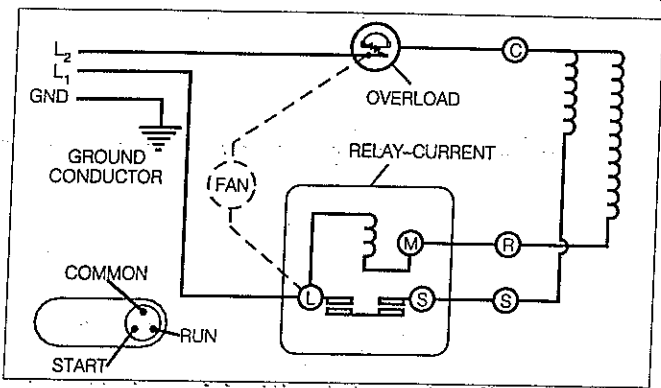

SCHEMATIC #1

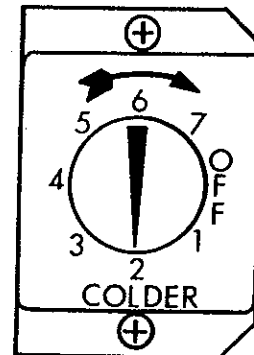

ILLUSTRATION #11

TROUBLESHOOTING:

PROBLEM	CAUSE	CORRECTIVE ACTION
VENDOR ACCEPTS COINS, BUT DOES NOT VEND ON ANY SELECTION	PLUG ON CONTROLLER UNPLUGGED OR LOOSE	CHECK THE WIRE CONNECTIONS AT BOTH ENDS OF WIRE HARNESS FOR GOOD CONNECTIONS.
	TRANSFORMER ASSEMBLY UNPLUGGED AT CABINET	CHECK THE WIRE CONNECTION AT BOTH ENDS OF THE WIRE HARNESS FOR GOOD CONNECTION
	BLACK AND WHITE WIRES UNPLUGGED AT REFRIGERATION SYSTEM	CHECK THE WIRE CONNECTIONS AT BOTH ENDS OF THE WIRE HARNESS FOR GOOD CONNECTIONS
	CIRCUIT BREAKER IN VENDOR TRIPPED OR BROKEN	RESET OR REPLACE CIRCUIT BREAKER
	DAMAGE OR DEFECTIVE POWER CORD	REPLACE POWER CORD
	VENDOR UNPLUGGED.	PLUG VENDOR IN.
	FUSE OR CIRCUIT BREAKER TRIPPED IN SUPPLY (BUILDING) OUTLET	RESET OR REPLACE
VENDOR REJECTS ALL COINS - DISPLAY LAMP ON	PLUG ON CONTROLLER UNPLUGGED OR LOOSE	CHECK THE WIRE CONNECTIONS AT BOTH ENDS OF THE WIRE HARNESS FOR GOOD CONNECTIONS.
	DO NOT HAVE 115 VOLTS	USE VOLT METER TO CHECK VOLTAGE BETWEEN THE TWO WIRES. CHECK THE WIRE CONNECTIONS AT BOTH ENDS FOR GOOD CONNECTIONS
	DEFECTIVE OR A BROKEN CIRCUIT	CHECK FOR ANY BREAKAGE AND GOOD WIRE CONNECTIONS.
	DO NOT HAVE 24 VOLT	CHECK WIRE CONNECTIONS AT BOTH ENDS OF WIRE HARNESS FOR GOOD CONNECTIONS AT TRANSFORMER
	BAD COIN MECHANISM.	REPAIR OR REPLACE COIN MECHANISM.
VENDOR ACCEPTS COINS, BUT DOES NOT VEND ON ANY SELECTION	BAD CONTROLLER BOARD	REPLACE CONTROLLER BOARD
	PLUG ON CONTROLLER LOOSE OR UNPLUGGED	CHECK WIRE CONNECTIONS AT BOTH ENDS OF WIRE HARNESS FOR GOOD CONNECTIONS.
	VEND PRICES SET WRONG	SET PRICES CORRECTLY
	BROKEN OR LOOSE WIRE FROM CONTROLLER TO SELECTION SWITCH, VEND SWITCH, SOLD OUT SWITCH, VEND MOTOR OR SOLENOID	CHECK WIRE CONNECTIONS AT BOTH ENDS OF WIRE HARNESS FOR GOOD CONNECTIONS.
	SOLD OUT SWITCH OR VEND SWITCH DEFECTIVE OR OUT OF ADJUSTMENT	RE-ADJUST OR REPLACE SWITCH.
	A DEFECTIVE MOTOR	REPLACE MOTOR
	VEND PRICES SET INCORRECTLY	SET PRICES CORRECTLY.
VENDOR VENDS PROPERLY, BUT PAYS OUT WRONG CHANGE OR NO CHANGE AT ALL	BAD CONTROLLER BOARD	REPLACE CONTROLLER BOARD.
	VEND PRICES SET INCORRECTLY	SET VEND PRICES PROPERLY
	CHANGER OUT OF CHANGE	FILL CHANGER INVENTORY TUBES
	DEFECTIVE COIN MECHANISM	REPAIR OR REPLACE COIN MECHANISM
PRODUCT DOES NOT MATCH SELECTION PUSHED	BAD CONTROLLER BOARD	REPLACE CONTROLLER BOARD
	PRODUCT LOADED WRONG	LOAD PRODUCT PROPERLY
	SELECTION SWITCH WIRES CROSSED, VEND MECHANISMS PLUGS CROSSED	MAKE SURE VEND MECHANISMS ARE PLUGGED IN CORRECTLY
VENDOR FREE VENDS	BAD CONTROLLER BOARD	REPLACE CONTROLLER BOARD
	VEND SWITCH DEFECTIVE OR OUT OF ADJUSTMENT	RE-ADJUST OR REPLACE SWITCH
BILL VALIDATOR DOES NOT ACCEPT BILLS	BAD COIN MECHANISM.	REPLACE OR REPAIR COIN MECHANISM.
	BAD CONTROLLER BOARD	REPLACE CONTROLLER BOARD
	CHANGER OUT OF CHANGE	FILL COIN TUBES
	VALIDATOR STACKER NOT CLOSED	CLOSE
	NO POWER TO BILL VALIDATOR	CHECK SUPPLY CIRCUIT
	BILL VALIDATOR DEFECTIVE	REPLACE
	FOREIGN OBJECTS IN VALIDATOR	CLEAN OR REPLACE

CARE & CLEANING:

CAUTION:

Always disconnect power source
BEFORE cleaning.

CABINET INTERIOR: Wash with a mild detergent and water, rinse and dry thoroughly. Odors may be eliminated by including baking soda or ammonia in the cleaning solution. Plastic parts may be cleaned with a quality plastic cleaner. **Do not get the cleaning solution on electrical components.**

CABINET EXTERIOR: Wash with a mild detergent and water, rinse and dry thoroughly. Clean occasionally with a quality car wax. Remove and clean Condensate Drain Hose to eliminate any deposits that may restrict condensate water flow.

REFRIGERATION SYSTEM: Clean dust from condenser and screen in the front door with a soft bristle brush or a vacuum cleaner. Remove any dirt or debris from the refrigeration system compartment. **If the condenser coil is not kept clean, the compressor will overheat or fail, voiding the sealed system warranty.** Clean the condensation pan.

OPERATION RECOMMENDATIONS:

During periods of peak sales we recommend the following to keep cans cool:

1. Fill the machine at night
2. Make sure to fill the machine with product from the pre-cool (rack on the door) first. Fill these racks with your top selling products.
3. double up selections on fastest moving flavors.
4. During peak selling days, keep extra product in cooler so that when filling machine the product is already cool.
5. Make sure after filling the machine the door is lock is tightened completely.
6. **DO NOT USE AN EXTENSION CORD!** The compressor will not cool the machine properly if it is starving for electricity.

7. Do not adjust the Cold Control beyond 2 1/2. Adjusting the cold control to a higher number does not accelerate the cooling of the product.

PARTS ORDERING PROCEDURE:

When ordering parts, include the following information:

1. Shipping address
2. address where the invoice should be sent.
3. The number of parts required.
4. Always refer to the pertinent parts and/or part manual for the correct part number and description of a specific part
 - a. If you do not have the right parts manual at the time you order, contact Selectivend, Inc., 165 North 10th Street, Waukee, Iowa 50263-0488. They will provide a copy to you.
Do not hold the order pending receipt of the parts manual; use the most accurate description you can (and the model number and serial number of the machine); include the name of the assembly in which the part is used and, if practical, a sample part. Furnish any information which will enable our Parts Department to pinpoint the exact part needed.
 - b. When "RIGHT" or "LEFT" is used in connection with the name of a part, if is taken to mean that the person is facing the machine with the door closed.
5. Always include the model number and serial numbers of the machine for which the parts are needed on the order.
6. List any special shipping instructions.
 - a. Always note on the order if you require air or air special, truck, parcel post or rail. Of a specific carrier is desired, note it on the order.
7. Sign the order and note the date entered on the order.
8. When a purchase order number is used, be sure that it is legible and visible.

MAIL YOUR ORDER TO:
SELECTIVEND, INC.
165 North 10th Street
Waukee, Iowa 50263-0488

All orders are carefully packed and inspected prior to shipment. Damage incurred during shipment should be reported at once and a claim filed with the terminating carrier.

BEFORE CALLING FOR SERVICE CHECK THE FOLLOWING:

1. Does your machine have at least 6" of clear air space behind it?
2. If the power is turned off at the fuse box is the machine the only thing that doesn't work?
3. Is the machine plugged directly into the wall outlet?

**EXTENSION CORDS INVITE TROUBLE!
DO NOT USE THEM**

4. Is the evaporator coil free of ice?
5. Is the condenser coil free of dust and dirt?
6. Has all soft drinks been pre-cooled before being put in the machine?
7. Is the compressor free of dust? (A blanket of dust can prevent the compressor from cooling off between workouts.
8. Has the circuit breaker in the fuse box been reset?
9. Is the cold control set between 2 & 3?
10. Are the evaporator fans running?

EVAPORATOR FAN TEST

Fold a sheet of 8 1/2 x 11 paper in half from top to bottom so it is not 5 1/2 by 8. Place the paper in front of the evaporator coil and see if the evaporator fans will draw the paper to the coil. If it does, the answer to question 10, is yes.

11. Is the condenser fan running?

CONDENSER FAN TEST

Fold a sheet of 8 1/2 x 11 paper in half. Place the paper in front of the condenser coils, and see if it draws the paper to the coils. If it does the answer to question 11, is yes.

12. Is the shelf in front of the evaporator coil clear?
(Free of cans, tools or other air restricting items)

